

TM9500 • TM13500



High Quality  
**TM Series Waterfall Pumps**  
Instructions for Operation • Safety • Warranty

Thank you for purchasing the TM series waterfall pump. This instruction manual explains the product operations and gives important precautions regarding its safe use. In order to use the product to maximum benefit, be sure to read the instructions thoroughly and follow them carefully.

To avoid accident, do not use the pump in any way other than as described in this instruction manual especially when you see "WARNING". After reading this instruction manual, keep it nearby as a reference in case questions arise during use.

If this instruction manual should become lost or damaged, ask your nearest dealer or representative for another copy.

### Safety & Electrical Connections



**WARNING:** Verify that the voltage and frequency of the electric pump shown on the nameplate correspond to those available on the mains.

The installer must make sure that the electric system is grounded in accordance with local ordinances.

The plug and connections should be protected from water/rain. Before using the pump, always inspect it visually (especially power cable and plug).

Do not use the pump if it is damaged.

If the pump is damaged, have it inspected by a qualified service center only.

Make sure that electric connections are protected from all water and moisture. Protect the plug and the power cable from heat, oil or sharp edges.



**WARNING:** The power cable must be replaced by qualified personnel only.

**Grounding:** The plug of the power cable has a double grounding contact, so that grounding can be performed by simply inserting the plug.

**Overload Protection:** EasyPro pumps have a built in thermal protection switch. The pump stops if an overload condition occurs. The motor restarts automatically after it has cooled down.

### Prior to Operation

Check the following points upon receipt of your pump:

Is the pump exactly what you ordered? Check nameplate. Has any damage occurred during shipment? Are any bolts or nuts loose? Have all necessary accessories been supplied? We recommend that you keep a spare pump on hand in case of emergencies. Keep this instruction manual in a place for future reference.



## Specifications

Model	HP	Watts	Max. Amps	Weight	Dimensions	Max. Head	Max. Flow
TM9500	1	750	10.9	52 lbs.	12" x 7.5" x 19.5"	31'	9500 GPH
TM13500	1.5	1125	12	58 lbs.	12" x 7.5" x 20"	33'	13500 GPH

## Pump Performance Chart

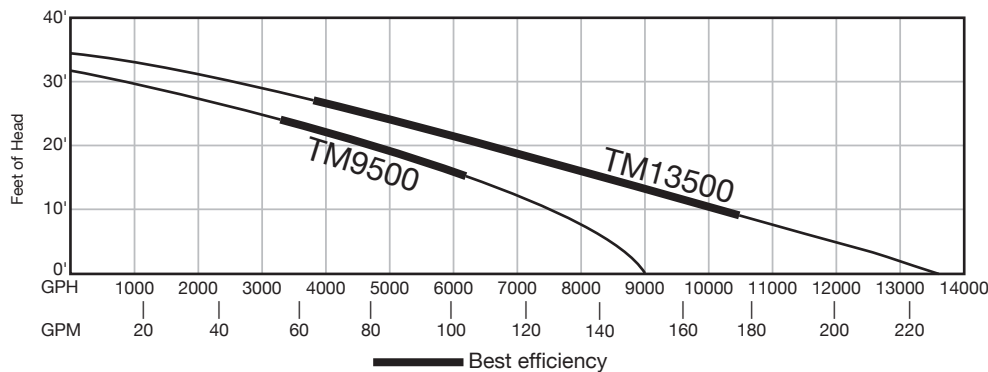

## Installation

### Symbol and Meaning:



**DANGER**

Keep the pump equipment out of the reach of children! Warns that failure to follow directions could cause serious risk/injury to individuals or objects.



**WARNING**

This sign warns the operator that the failure to follow an instruction may damage the pump and/or the system.

### Limitations:

This series of pumps are suitable to pump rain water and also can be used both for permanent and temporary installation. The pump can be placed in a sump pit, then can pump dirty water containing suspended solid particles up to 1/2" diameter.



**WARNING:** The pump cannot be used for sea water and flammable, corrosive, explosive or dangerous liquids.

### Installation:

#### WARNING:

Do not work on pump until power is unplugged.

Do not cut off ground pin or use an adapter fitting.

Do not use an extension cord

Must be used on a GFCI protected outlet

Do install the strainer prior to using if you want to let the pump run as a sump pump.

The pump power cord should be connected to a separately fused, grounded line with a minimum capacity of 15 amps. It can be connected to non-fuse breaker at the recommended amps. Never touch the pump when it is plugged in.

1. Before installing or servicing this pump, be certain pump power source is disconnected. Contact a qualified licensed electrician for disconnecting electrical service prior to pump removal.
2. Installation and electrical wiring must adhere to state and local codes and must be completed before priming pump. Check appropriate community agencies, or contact local electrical and pump professionals.
3. Call an electrician when in doubt. Pump should be connected to a separate 15 amp circuit breaker or 15 amp fuse block. Note that, plugging into existing outlets may cause low voltage at motor, causing blown fuses, tripping of motor overload or burned out motor.
4. A permanent ground connection from pump to the grounding bar at the service panel is mandatory. For maximum safety, connect pump to a circuit equipped with a Ground Fault Circuit Interrupter device when you position the pump's grounding wire.
5. Voltage of power supply must match the voltage of the pump.



**WARNING:** Must be vented in accordance with local plumbing codes. EasyPro pumps are not designed for and CANNOT be installed in locations classified as hazardous.



**WARNING:** The following may cause severe damage to pump and will void warranty:

- Using an extension cord
- Cutting off the ground pin or using an adapter fitting
- Working on pump or switch while plugged in
- Removing motor housing, unscrewing impeller or otherwise removing impeller seal
- Pumping chemicals or corrosive liquids
- Pumping gasoline or other flammable liquids
- Piping: Plastic PVC pipe, drain hose, galvanized steel or copper pipe may all be used. All piping must be clean and free of all foreign matter to prevent clogging. Use thread compound on all threaded joints unless specified otherwise. Be sure to seal the thread connection with tape seal when you are using the pipe fitting to connect the flange.

## Replacement Parts

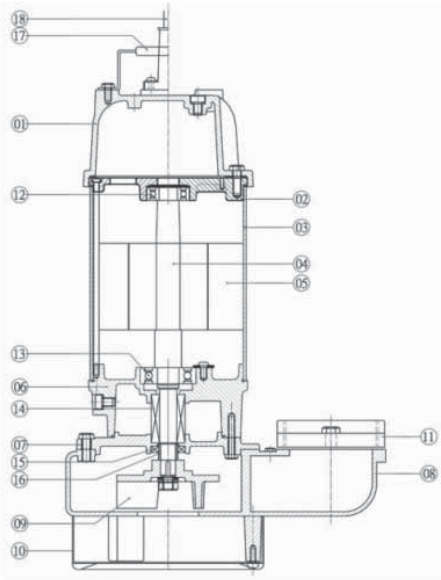

NO.	Description	Material	Q'ty
01	Motor Cap	FC200	1
02	Upper Bearing Cover	FC200	1
03	Motor Housing	SUS340	1
04	Rotor	SUS410	1
05	Stator	C60	1
06	Seal Cover	FC200	1
07	Oil Seal Cover	FC200	1
08	Pump Casing	FC200	1
09	Impeller	FC200	1
10	Strainer	SUS	1
11	Flange	FC200	1
12	Upper Bearing		1
13	Lower Bearing		1
14	Mech. Seal	SIC/SIC+CA/CE	1
15	Oil Seal	NBR	1
16	Shaft Sleeve	SUS	1
17	Handle	NBR+SUS	1
18	Power Cord		1

## Troubleshooting

<i>Problem</i>	<i>Possible Causes</i>
<b>Pump hums</b>	<ul style="list-style-type: none"> <li>• Line circuit breaker is off, or fuse is burned or loose.</li> <li>• Water level in sump has not reached turn-on level as indicated in installation drawing on the carton.</li> <li>• Pump cord is not making contact in receptacle.</li> <li>• Float (optional) is stuck. It should operate freely in basin.</li> <li>• If all of the above are OK and then the motor should operate.</li> </ul>
<b>Pump runs but does not deliver water</b>	<ul style="list-style-type: none"> <li>• Check valve (optional) is installed backwards (not included with pump), arrow on valve should point in direction of flow.</li> <li>• Discharge shut-off valve (if used) may be closed.</li> <li>• Impeller or volute openings are fully or partially clogged, remove pump and clean.</li> <li>• Pump is air-locked, start and stop several times by plugging and unplugging cord, check for clogged vent hole in pump case.</li> <li>• Inlet holes in pump base are clogged, remove pump and clean the openings.</li> <li>• Vertical pumping distance is too high or the pipe size is too small, reduce vertical distance or increase the pipe size fittings.</li> </ul>
<b>Pump runs but delivers only a small amount of water</b>	<ul style="list-style-type: none"> <li>• Pump is air-locked, start and stop several times by plugging and unplugging cord, check for clogged vent hole in pump case.</li> <li>• Vertical pumping distance is too high or pipe size is too small, reduce vertical distance or increase the pipe size.</li> <li>• Inlet holes in pump base are clogged, remove pump and clean the openings.</li> <li>• Impeller or volute openings are fully or partially clogged, remove pump and clean.</li> <li>• Pump impeller is partially clogged with debris, causing motor to run slow and overload, remove pump and clean.</li> </ul>
<b>Fuse blows or circuit breaker trips when pump starts</b>	<ul style="list-style-type: none"> <li>• Pump impeller is partially clogged with debris causing motor to run slow and overload, remove pump and clean.</li> <li>• Motor stator may be defective.</li> <li>• Fuse size or circuit breaker may be too small (must be 15 amps).</li> <li>• Impeller or volute opening are fully or partially clogged, remove pump and clean.</li> </ul>
<b>Motor runs for a short time, then stops</b>	<ul style="list-style-type: none"> <li>• Inlet holes in pump base are clogged, remove pump and clean the openings.</li> <li>• Pump impeller is partially clogged with debris causing motor to run slow and overload, remove pump and clean.</li> <li>• Motor stator may be defective.</li> </ul>

**Limited Warranty:**

- This product is warranted against any mechanical or material defects for a period of two years from the date of purchase
- This warranty does not cover accidental damage to the product due to abuse or negligence by the consumer.
- An RMA number must be obtained by calling EasyPro Pond Products at 800-448-3873 and be included on package before returning for warranty issues.

Return warranty items to:

EasyPro Pond Products, 4385 East 110th, Grant, MI 49327

*Be sure to include RMA number, original receipt, name, return address and phone number in package.*

- In the event of a warranty claim, please return the pump postage prepaid with the original receipt for repair or exchange. No warranty claims will be honored without the original receipt.
- The manufacturer or supplier shall not be held liable for any damages caused by defective components or materials of this pump; or for loss incurred because of the interruption of service; or any consequential/incidental damages and expenses arising from the production, sale, use or misuse of this product.
- The manufacturer or supplier shall not be held liable for any loss of fish, plants or any other livestock as a result of any failure or defect of this product.
- If you experience a failure of your pump, please check the following before returning to us:
  1. Remove filter housing, clean and inspect impellar and surrounding chamber, reassemble and test pump;
  2. Verify electrical supply.

*Each year we receive numerous pumps back that simply have a small stone lodged in the impellar, are plugged from lack of cleaning or do not work due to low voltage caused by an overloaded circuit. These are not warranty items. Please take the time to verify your problem is actually a defective pump before returning. EasyPro will pay postage to return pump to you provided it is a warranty issue. If you send a pump in for warranty and it checks out fine — you will also be responsible for the cost of return postage.*

Return  
warranty  
pumps to:

EasyPro  
Pond Products  
4385 East 110th  
Grant, MI 49327

Be sure to include  
RMA number, original  
receipt, return  
address and phone  
number in package!



800-448-3873 • Grant, Michigan  
www.EasyProPondProducts.com • info@EasyProPondProducts.com