



## Instruction Manual

Skimmer Part No. PS3900  
FilterFalls Part No. BF1600  
Pump Vault Part No. PV1700  
FastFalls Part No. SP1600

1-877-80-PONDS  
[www.atlanticwatergardens.com](http://www.atlanticwatergardens.com)

# Table of Contents

Product Overview	Page 3
<b><u>WATER GARDENS</u></b>	
Determining Pond Volume	Page 4
Determining Surface Area	Page 4
Streambed Construction	Page 5
Placement of FilterFalls and Skimmer	Page 5
<b>SKIMMER INSTALLATION</b>	
Excavating and Setting the PS3900	Page 6
Attaching the Liner	Page 6
Attaching the Weir Door	Page 7
Plumbing the PS3900	Page 8
<b>FILTERFALLS INSTALLATION</b>	
Bulkhead Installation	Page 8
Setting the BF1600	Page 8
Liner Attachment	Page 9
<b><u>POND-FREE</u></b>	
Eco-Blox vs. Gravel	Page 10
Streambed Volume	Page 10
Basin Volume	Page 10
<b>PUMP VAULT INSTALLATION</b>	
Excavating and setting the PV1700 (Waterfall)	Page 11
Plumbing the PV1700 (Waterfall)	Page 11
Excavating and setting the PV1700 (Fountain)	Page 12
Plumbing the PV1700 (Fountain)	Page 12
<b>FASTFALLS INSTALLATION</b>	
Setting the SP1600	Page 13
Liner and Plumbing Attachment	Page 13
Hiding the SP1600	Page 14
<b>SKIMMER / PUMP VAULT ACCESSORIES</b>	
Triton Check Valve	Page 15
AF1000 AutoFill Kit	Page 16
Skimmer Overflow	Page 16

**This manual contains basic construction techniques and installation instructions for Atlantic Oasis Series Pond and Pond-Free products. For more in-depth information regarding water feature construction, techniques and maintenance, please visit:**  
**[www.atlanticwatergardens.com/university/awguniversity.html](http://www.atlanticwatergardens.com/university/awguniversity.html)**

### FilterFalls BF1600



1½" heavy-duty bulkhead

### Skimmer PS3900

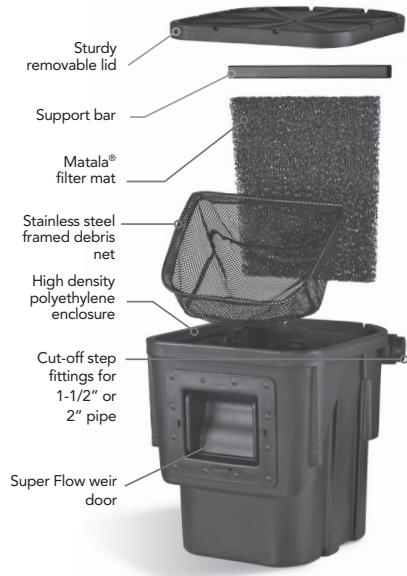

### Pump Vault PV1700



back



Cut-off step fittings for 1 ½" or 2" pipe

### FastFalls SP1600



back



Installed 1 ½" FIPT Spinweld® fitting  
Liner flange and molded inserts ensure a secure liner attachment

# Water Gardens

## POND VOLUME

It is important to calculate the estimated water volume before you begin construction, and then re-calculate final water volume when your project is completed. Estimating water volume pre-construction is a step that is often skipped by many homeowners and contractors. A water garden with undersized filtration can prove to be a maintenance nightmare.

Oasis Skimmer and FilterFalls can accommodate flow rates up to 3900 GPH and filter ponds up to 1500 gallons in volume.

### TO DETERMINE POND VOLUME

*Multiply (in feet) the average length x the average width x the average depth to find cubic feet of pond volume. Multiply cubic feet x 7.48 = gallons*

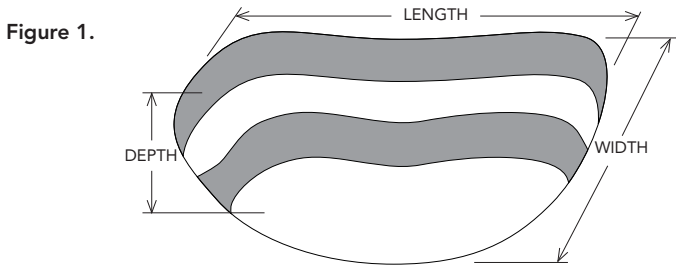

## SURFACE AREA

When using any pond skimmer it is important to keep the surface area (in square feet) of the pond in mind. Upon start-up, the pump sends water from the bottom reservoir to the top of the waterfall and/or streambed. The water must then fill, from top to bottom, the waterfalls and streambed until it eventually re-enters the pond and the water levels equalize. During water in transition process, the water level of the bottom reservoir is continually dropping. If the streambed is built improperly, or is built too big, the water level of the bottom reservoir could drop below the opening in the skimmer before the water levels equalize. This would result in the pump running dry and starving for water.

This situation can be easily avoided by using the formula provided to calculate the surface area of your pond. With that number, you can then determine the maximum surface area of waterfalls and streambed that your pond can accommodate.

### TO DETERMINE SURFACE FOOTAGE

*Multiply (in feet) the average length x the average width = total square feet of the pond surface area. Multiply the surface area of the pond x .5 = maximum surface area for falls*

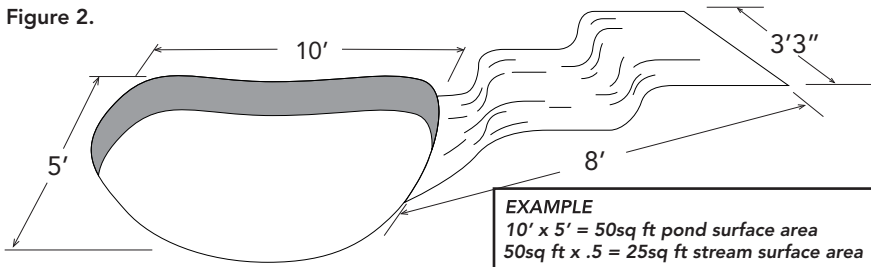

## STREAMBED CONSTRUCTION

Using proper streambed construction techniques can limit the transitional water needed to fill the streambed and enables the system to function optimally. Transitional water is determined by the height that the weir rock extends above the liner at the spillway opening. Maintaining the shortest distance possible between the top of the weir rock and the liner is a crucial component to a properly functioning water garden. Figure 3 displays two examples of proper construction techniques for minimal transitional water.

Figure 3.

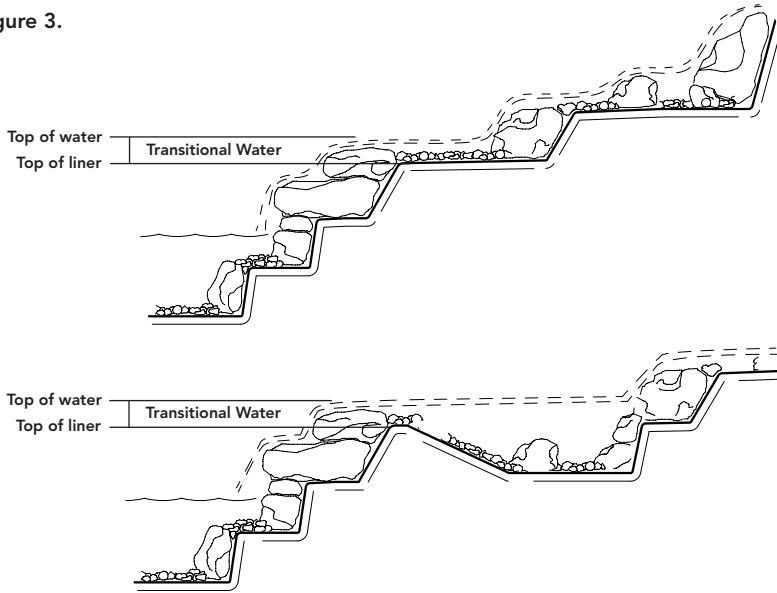
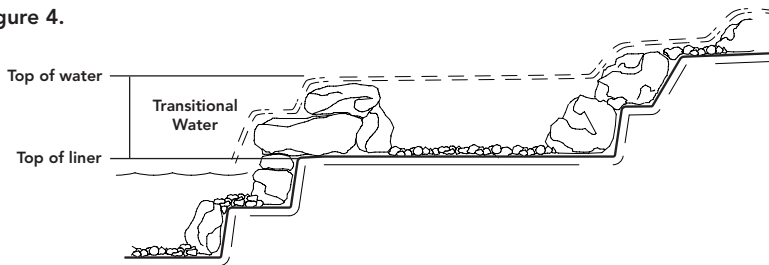

Figure 4 is an example of improper streambed construction. Stone, gravel and foam can be combined to make a barrier and create a waterfall, but that barrier will never be watertight. When the pump is turned off, the water will always drain down to the highest point of the liner. Improper construction greatly increases the water in transition.

Figure 4.



## PLACEMENT OF THE FILTERFALLS AND SKIMMER

Now that you have determined the size of the pond, waterfalls and filter system, it is time to determine the placement of the components.

Whenever possible, it is best to position the Skimmer and FilterFalls directly across from each other at opposite ends of the pond. This setup creates a current that pulls surface debris into the Skimmer. If the Skimmer and FilterFalls are placed too close together, or the pond has an unusual shape, dead areas can occur. These dead areas can be eliminated with the use of multiple falls or multiple skimmers.

# Oasis Skimmer Installation

## EXCAVATING AND SETTING THE PS3900

Prior to setting the skimmer you must first determine the surface level of the water in the pond. Once you have this number you can excavate for the Skimmer. The excavation should be a few inches wider and longer than the Skimmer body. The depth of excavation for the PS3900 should be 15" below water level. **Do not dig too deep.** The skimmer should be set on stable, compacted soil. In the case that you over-dig, be sure to compact the soil thoroughly to prevent settling. The bottom of the hole should be level side-to-side and front-to-back (Figure 5).

Figure 5.

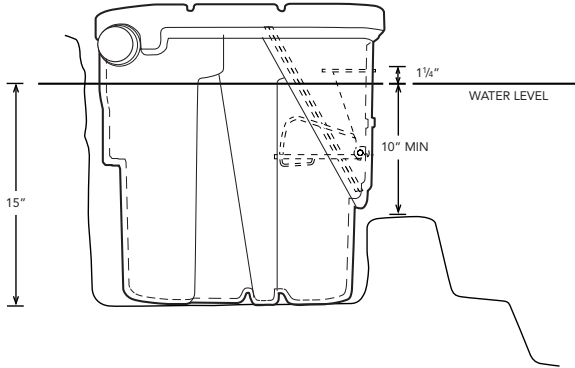

Place the skimmer enclosure into the excavated hole. Check the top of the enclosure to make sure that it is level front-to-back and side-to-side. Check where your pre-determined water level falls on the face of the skimmer enclosure. Water level should be 1/4" below the top of the weir door opening.

Make sure that any unexcavated soil that is left in front of the Skimmer is at least 10" below water level. This will ensure that there is enough room for the weir door to be installed and function properly.

Before you go any further into the Skimmer installation, it is a good idea to place a few stones inside the Skimmer enclosure to weigh it down and keep it from moving.

Prior to backfilling the enclosure, make sure the support bar is installed inside the skimmer. The support bar must be in place for the enclosure to retain its shape during the backfilling process. Loosely backfill the enclosure on all sides, lightly compacting as you go. Do not over-compact the soil! Aggressive compaction may deform the enclosure and cause components to fit improperly.

## ATTACHING THE LINER

Hold the liner up against the face of the Skimmer, allowing a minimum of 2" to extend above the top of the enclosure. Leave some excess slack in the liner below the weir opening. This will help alleviate any future strain on the liner connection.

Make sure that the front surface of the Skimmer, and the back side of the liner, are clean and free of debris. When you are satisfied with the position of the liner, clip it in place with the provided spring clips. With a sharp razor knife, cut a hole in the liner for the weir door using the hole in the face of the skimmer as a guide (Figure 6).

When you are finished, remove the spring clips and pull the liner away from the face of the skimmer. Apply a consistent bead of Atlantic fish-safe silicone to the face of the Skimmer along the centerline of the pre-drilled bolt holes. Once you are finished, you can return the liner to its original position and replace the spring clips.

Figure 6.

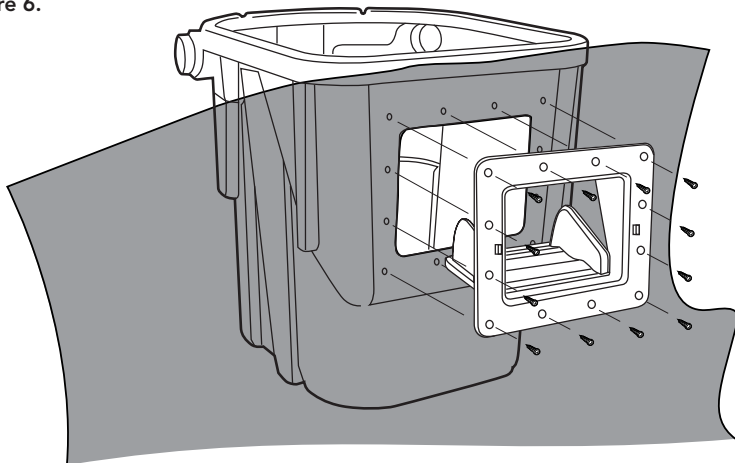

### ATTACHING THE WEIR DOOR

Unlatch the weir door and lower the door to its fully open position. Insert the weir door assembly into the Skimmer opening. With one hand push the bottom of the weir door frame tight against the Skimmer face. With the other hand gently push down on the weir door latch until it clears the top of the opening. Once it does, push the weir door assembly into the Skimmer opening until the frame rests against the face of the enclosure (Figure 7).

Line up the holes of the weir door frame with the holes in the Skimmer face. Use a nail or awl to help line up the holes and pierce the liner in the top corners. Loosely fasten the top corners using two of the supplied 1/4-20 machine screws and serrated flange nuts. Next, install two screws in the bottom corners of the weir door frame (Figure 8).

Once you have the weir door tacked at the corners you can install the rest of the screws. Do not fully tighten any screws until all of the screws have been installed.

Figure 7.

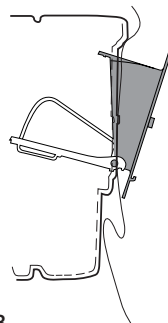
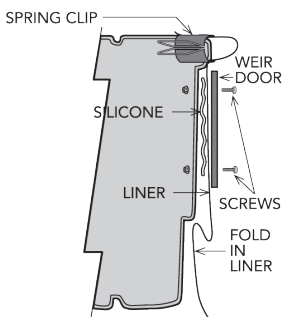

Figure 8.



Use your fingers to hold the flange nut and a hand held screwdriver to tighten the screws. The serrations on the flange nut will grab the plastic enclosure once it makes contact, eliminating the need to use a wrench. Use caution when tightening the screws. The screws need only be snug for the silicone to make a seal.

## PLUMBING THE PS3900

The PS3900 Skimmer has pump discharge step fittings molded into each side of the skimmer enclosure. The step fittings are labeled for 1 ½" or 2" PVC pipe and have cut lines molded in for each size (Figure 9). Choose the step fitting on the side of the skimmer that will be best suited to exit based on this installation. Using a PVC saw or standard hack saw, remove the end of the step fitting (making sure to follow the molded cut line) for the size pipe used for this water feature. Once completed, push one end of the PVC supply line through the step fitting allowing approximately 10" of pipe to enter the skimmer enclosure.

It is recommended that you install a TR215CV Triton Check Valve between the pump and the supply line. This valve will prevent the FilterFalls from draining when the pump is off, which keeps the beneficial bacteria alive and any debris that the FilterFalls has collected from back flowing into your pond. Refer to the Triton Check Valve installation instructions on page 15 for further details.

A drill point is provided on both sides of your Oasis Skimmer to show the proper location for the installation of an AF1000 Auto Fill valve (not included). See the Auto Fill installation instructions on page 16 for more information. There is a drill-point provided on the back of Oasis Skimmer to show the proper location and elevation for the installation of an overflow (not included). See the Overflow installation instructions on page 16 for more information.

Figure 9.

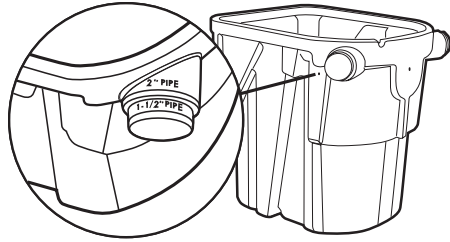

# Oasis FilterFalls Installation

## BULKHEAD INSTALLATION

It is a good idea to install the bulkhead fitting and 1 ½" MTA (included) before setting the BF1600. If 2" flexible PVC is being used for the supply line, replacing the 1 ½" HA1550 bulkhead with an Atlantic 2" HA2000 bulkhead (not included) is recommended.

Remove the retaining nut and plastic friction washer, leaving the rubber gasket on the body of the bulkhead fitting. Note that the retaining nut is reverse threads. Turn clockwise to loosen.

From the inside of the FilterFalls, insert the threaded end of the bulkhead into the hole on the back of the enclosure. This will sandwich the rubber gasket between the flange of the bulkhead and the inside wall of the enclosure. Slip the friction washer over the threaded end of the bulkhead on the outside of the enclosure and install the retaining nut. Tighten the retaining nut by hand and then finish off with a half turn from a wrench. Note that the retaining nut is reverse threads. Turn counterclockwise to tighten.

## SETTING THE BF1600

It is always recommended that the FilterFalls be placed on undisturbed soil if possible. If the installation calls for the FilterFalls to be elevated above existing grade, it is critical to compact the area thoroughly. This will ensure that the FilterFalls will not settle out-of-level over time. The use of cinder blocks or bricks under the falls to raise it up will help reduce the chance of settling.

The FilterFalls can be placed adjacent to the pond edge to create a single waterfall, or pulled away from the pond to create a streambed effect. Refer to the surface area recommendations on page 4 to ensure that the streambed is properly sized.



Once you have placed the unit, make sure it is level from side to side and check the level from front to back. FilterFalls should always be installed tilted slightly forward about  $\frac{1}{4}$ ". This will ensure that water never leaks out over the back of the enclosure. When you are finished positioning the unit, it is a good idea to weigh it down with a few rocks to keep it in place while you backfill and make your liner and plumbing connections. Apply silicone on the threads of the Male Thread Adaptor (MTA). Screw the MTA into the bulkhead until tight. Use PVC Glue (not included) to glue the PVC flex hose into the MTA.

**Do not completely backfill the FilterFalls until all of your plumbing connections are made and the liner has been attached.**

## LINER ATTACHMENT

Atlantic FilterFalls come equipped with a solid spillway, threaded inserts and a 'U' shaped wrap-around flange to provide the best possible seal.

Start by positioning the liner. Pull the liner up the face of the FilterFalls and drape a minimum of 6" of liner over the top of the enclosure. Use the provided spring clips to temporarily hold the liner in place (Figure 10). Leave some excess slack in the liner below the spillway. This will help to alleviate any future strain on the liner connection. With the liner firmly in place, use a sharp razor knife to cut the spillway opening in the liner using the inside of the spillway as a guide (Figure 10).

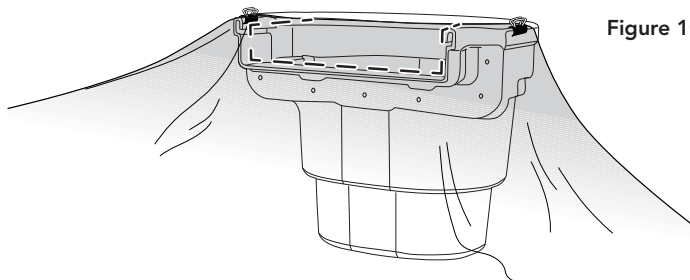

Figure 10.

Remove the spring clips and pull the liner away from the face of the enclosure. Make sure that the front of the FilterFalls and the back side of the liner are clean and free of debris. Apply a consistent bead of Atlantic fish-safe silicone to the face of the FilterFalls along the center line of the threaded inserts.

Return the liner to the face of the FilterFalls and hold it in place by attaching the spring clips to the rolled lip on either side of the spillway (Figure 11).

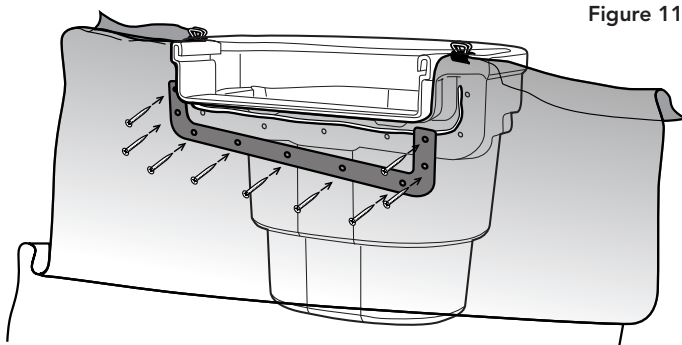

Figure 11.

Attach the liner flange to the FilterFalls, starting with the center screw first, and then work out toward the sides of the spillway. It may be necessary to first pierce the liner with a nail or an awl before inserting the screw. Do not fully tighten any screws until all the screws have been installed. Once completed, trim away any excess liner as needed.

**Tighten flange screws with a hand held screwdriver only. Over tightening the screws could strip out the inserts or crack the liner flange. The screws need only to be snug for the silicone to make a seal.**

## POND-FREE

Pond-free features exchange the open water of the pond for a gravel-topped excavation, maximizing visual impact while minimizing headaches and maintenance. Typically, a pump placed in a protective vault inside a lined reservoir continuously recirculates water over a stream or waterfall. A bed of gravel hides the basin, vault and plumbing from view, leaving only the stream and waterfall visible.

### ECO-BLOX vs. GRAVEL BASIN for a WATERFALL or STREAM

Eco-Blox basins consist of 10% Eco-Blox and 90% water. Gravel basins consist of 70% rock and only 30% water. As a rule of thumb, your pond-free basin should hold three times the amount of water as the waterfalls and streambeds above it. It is critical to calculate the water volume that the basin can hold before you begin construction of the waterfalls or streambed.

**Why should the basin be three times the size of the stream?** Upon start-up, the pump sends water from the bottom reservoir to the top of the waterfall and/or streambed. The water must then fill, from top to bottom, the waterfalls and streambed until it eventually re-enters the basin and the water levels equalize. During this filling process, the water level of the bottom reservoir is continually dropping.

If the streambed is built improperly, or is built too big, the water level of the bottom reservoir may drop below the top of the pump before the water levels equalize. This would result in the top of the pump being exposed to air. Pumps must be completely submersed in water or they can overheat causing damage to the pump. Refer to the streambed construction section on page 5 for more detail.

### STREAMBED VOLUME

*Multiply (in feet) the average length x the average width x the average depth to find cubic feet of streambed volume*

$$2'' \text{ DEEP} = 0.16'$$

$$3'' \text{ DEEP} = 0.25'$$

$$4'' \text{ DEEP} = 0.33'$$

**Don't forget that the thickness of your rocks will add extra depth to the water. (e.g. if you have rocks 1" deep covering the bottom of your stream, be sure to incorporate that 1" into your total depth)**

### BASIN VOLUME

*For Eco-Blox: Multiply the cubic feet of the streambed x 3 = cubic feet needed for the basin  
Cubic feet ÷ 4.2 = the number of Eco-Blox*

*For Gravel: Multiply the cubic feet of the streambed x 9 = cubic feet needed for the basin  
Cubic feet ÷ 19 = the number of tons of gravel*

# Oasis Pump Vault Installation

The PV1700 is Atlantic's most compact, easy to install pump vault. The PV1700's features include an incredibly strong enclosure, recessed panels on the front that can accommodate Triton 3-Way Diverters, cut lines on the back for 1½" and 2" pump discharges, and marked drill points on the left and right sides for an Auto Fill.

## EXCAVATING AND SETTING THE PV1700 for a WATERFALL or STREAM

Once you have determined the proper size basin for your project, begin by deciding the placement of the vault. The vault should be placed away from the waterfall where the lid can be accessed easily. The PV1700 flat panel will sit flush against the Eco-Blox, so that water can enter the pump vault. The area where the pump vault will sit should be dug 22" deep for the PV1700. When using Eco-Blox, the pump vault will recess lower than the Eco-Blox (Figure A). The area for the Eco-Blox to sit should be dug 18" deep.

Figure A.

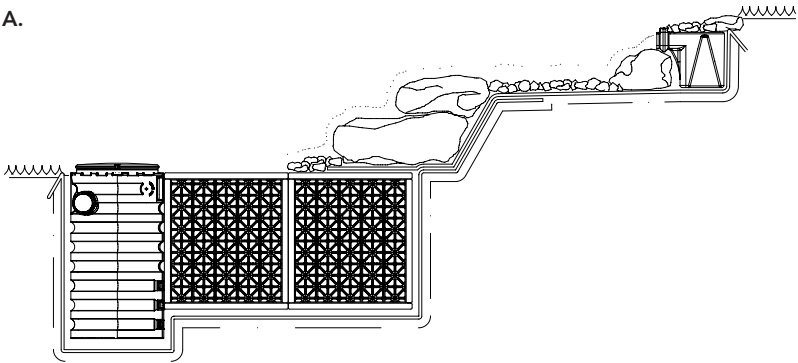

Once excavation is complete, install underlayment, pond liner, Eco-Blox and pump vault. Backfill the space between the Eco-Blox and the excavation to lock them into place, either outside the liner with sand or clean fill, or inside the liner with gravel ¾" or larger in diameter. Top the liner and basin with ¾" or larger gravel or decorative stone. Smaller, more decorative gravel, landscape glass, etc. can be used to cover the top of the basin, provided a denser mesh is installed beneath the material.

## PLUMBING THE PV1700 for a WATERFALL or STREAM

The PV1700 has pump discharge step fittings molded into each side of the enclosure. The step fittings are labeled for 1½" or 2" PVC pipe and have cut lines molded in for each size (Figure B). This allows the installer the flexibility to exit out the left or right side. The flat panel on the back is for an overflow. The two drill points near the top of the left and right sides are for the installation of an Auto Fill (See Auto Fill and Overflow instructions on pg. 16).

Figure B.

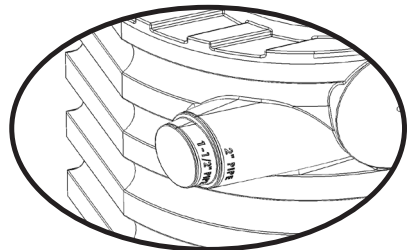

## EXCAVATING AND SETTING THE PUMP VAULT FOR A FOUNTAIN

The capacity of the basin will vary depending on the size, height and number of the decorative fountain elements. For a general rule of thumb, make the basin at least twice the width of the fountain piece or fountain pieces at their widest point. To capture the splash from taller pieces or more aggressive flows, where added storage capacity isn't desired or needed, excavate a shallow 2-3" deep bowl around the basin and extend the liner out to at least twice the height of the decorative elements (Figure C). This technique will recapture as much water as possible with minimum additional excavation. Consider increasing the storage capacity by incorporating Rainwater Harvesting into your design. For further information see our website [www.atlanticwatergardens.com](http://www.atlanticwatergardens.com).

Once you have determined the approximate size of the basin, lay out the Eco-Blox and PV1700.

The PV1700 should be placed away from the fountain piece where the lid can be accessed easily. Place the flat panel of the PV1700 up against the Eco-Blox so water can enter through the ports.

Tailor the excavation to the shape of the Eco-Blox and PV1700 so the vertical walls of the basin will support the outside walls of the Eco-Blox, leaving a few extra inches all of the way around to make installation easier.

Dig the entire basin down to 17" below grade and carefully level the bottom of the excavation. This depth ensures the plumbing fittings exit out on top of the Eco-Blox. Install the underlayment and liner, then the Eco-Blox and PV1700.

Backfill the space between the Eco-Blox and the excavation to lock them into place, either outside the liner with sand or clean fill, or inside the liner with gravel  $\frac{3}{4}$ " or larger in diameter. Top the liner and basin with  $\frac{3}{4}$ " or larger gravel or decorative stone. Smaller, more decorative gravel, landscape glass, etc. can be used to cover the top of the basin, provided a denser mesh is installed beneath the material.

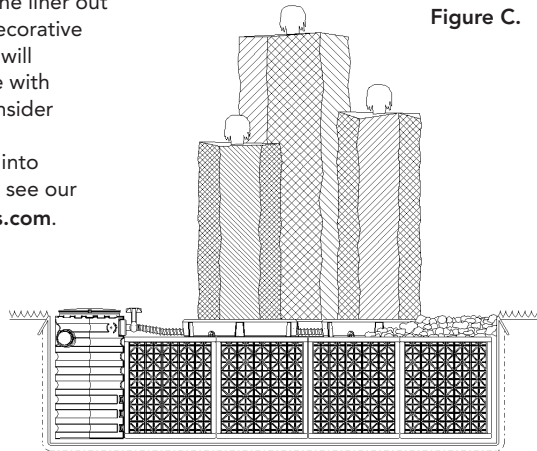

## PLUMBING THE PV1700 FOR A FOUNTAIN

The recessed panels on the front right and left are designed to accommodate up to two optional Triton 3-Way Diverter, to allow plumbing and individual valving of up to six separately controlled decorative elements. To install, drill a 2  $\frac{1}{4}$ " hole with a hole saw (not included). The center point of the hole is marked on the panel.

The center raised area on the front of the PV1700 can be drilled for a single discharge of up to 1  $\frac{1}{2}$ " PVC pipe. Your pipe size will determine the size of the hole to drill. The flat panel on the back is designed to accommodate an overflow. The two drill points near the top of the left and right sides are for the installation of an Auto Fill (See Auto Fill and Overflow instructions on pg. 16).

# Oasis FastFalls Installation

## SETTING THE SP1600

Place the Oasis FastFalls on a level bed of undisturbed soil if possible, to avoid settling. If installing above existing grade, compact the area thoroughly. This critical step will ensure that the FastFalls will not settle out of level over time. Blocks or bricks set on virgin soil can also be used to raise the FastFalls while reducing the chance of settling.

Place the FastFalls right at the pond's edge to create a single dramatic fall, or pull the FastFalls back from the edge to create a stream. Leave plenty of liner around the FastFalls to make it easy to camouflage with rock later.

To ensure a leak-proof installation, test place the FastFalls in the desired location and level it from side-to-side and front-to-back. The closed design of the FastFalls ensures that water will only exit the unit over the spillway, so there is no need to tilt the FastFalls forward.

When you are satisfied with the placement of the FastFalls, remove the unit and install the liner and underlayment, being careful not to disturb the level base. Place the FastFalls on top of the liner in its original position. Check the unit for level to ensure that nothing has changed. Once the FastFalls is level and positioned correctly, place a couple of large stones on top of the FastFalls. This will ensure that the FastFalls does not move when backfilling and attaching liner (Figure D).

Figure D.

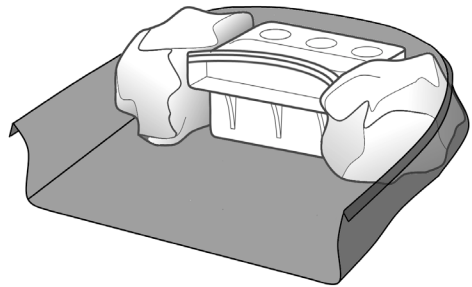

## LINER AND PLUMBING ATTACHMENT

Hold the liner up against the flat panel on the back of the Oasis FastFalls enclosure. Leave some excess slack in the liner below the spinweld. This will help alleviate any future strain on the liner connection. Make sure the back surface of the FastFalls, and the back side of the liner is clean and free of debris. Once you are satisfied with the position of the liner, lower it down and prepare to apply the silicone sealant (Figure E).

Figure E.

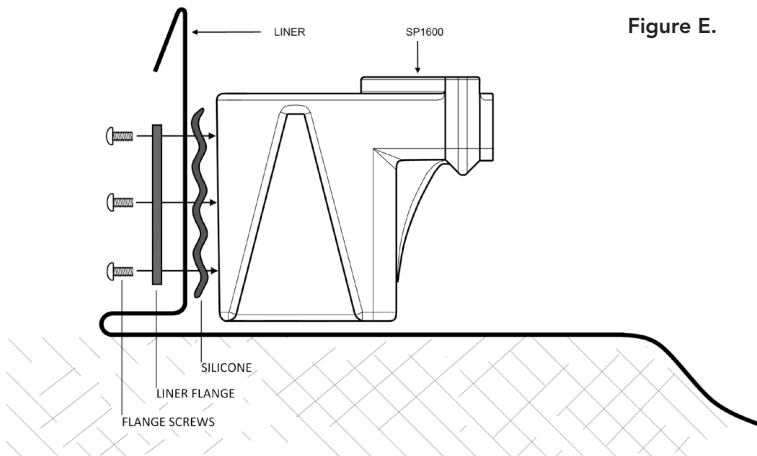

Apply Atlantic's Silicone Sealant in a continuous, consistent bead along the center of the threaded inserts. Once completed, return the liner to its dry-fit position.

Attach the supplied flange to the FastFalls, starting with the top screw first, working around the flange. If needed, use an awl or nail to pierce the liner before inserting the screws. Do not fully tighten any screws until all of the screws have been installed. Once completed, trim away the liner on the inside of the flange (Figure F).

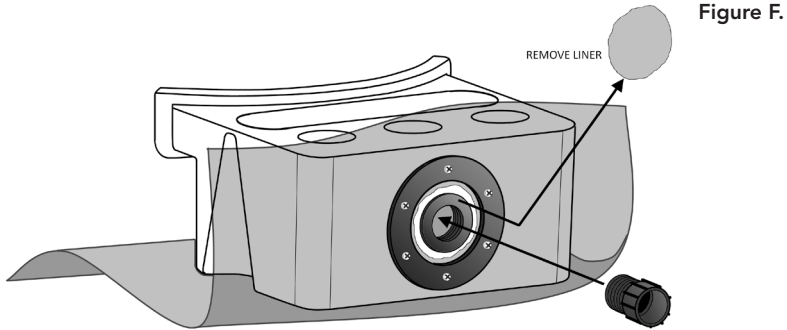

**Tighten flange screws with a hand held screwdriver only. Over tightening the screws could strip out the inserts or crack the liner flange. The screws need only to be snug for the silicone to make a seal.**

Apply silicone on the threads of the Male Thread Adaptor (MTA). Screw the MTA into the spinweld until tight. Use PVC Glue (not included) to glue the PVC flex hose into the MTA.

### HIDING THE OASIS FASTFALLS

Position rocks on either side of the Oasis FastFalls, inside the liner (Figure D). Start working the rock in and around the front of the FastFalls, building up to the lip of the FastFalls, which will provide support for a lip rock. The Fastfalls will support the weight of gravel and rocks, stacked directly on top of the unit. The FastFalls easily supports the weight, so consider covering the whole unit with a single sizeable overhanging capstone, or stack individual smaller stones and gravel on top to completely conceal the FastFalls (Figure G). For a 'grown-in' look, cover the FastFalls with soil and plant small evergreens and perennials right on top. The raised lip will keep the gravel or soil from washing into the water.

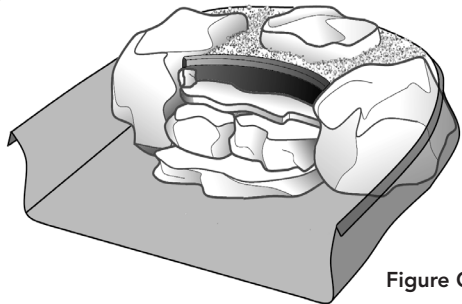

# Skimmer/ Pump Vault Accessories

## TRITON CHECK VALVE

Locate the model number of the TidalWave pump used for this installation on the chart. The 'perfect cut' reference mark is listed next to the pump. If the corresponding reference mark is a letter, then the 1 1/2" threaded end of the discharge pipe will be used. If the corresponding reference mark is a number, then the 2" threaded end of the discharge pipe will be used.

Discharge Pipe  
PS3900 & PV1700 Reference Chart

MD1000 / 1250 / 1500 / 2000	B
TW1900 / 2400 / 3700	B
SH1450 / 2050 / 3600	E
PAF-20 / 25	3
A-05	3

Locate the correct reference mark for this installation on the discharge pipe. Using a hacksaw or PVC saw, cut the pipe at this mark being careful to make a clean, square cut (Figure H). Discard the end of the discharge pipe that will not be used.

Figure H.

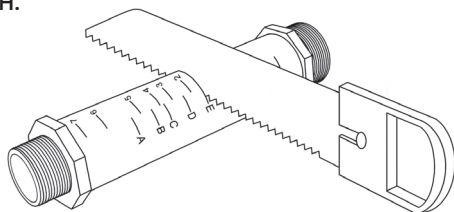

Use a small piece of sandpaper to smooth out the cut end of the discharge pipe. Clean the 2" socket fitting on the bottom of the check valve and the cut end of the discharge pipe with PVC cleaner/primer. Apply PVC glue and insert the discharge pipe into the 2" socket fitting. Hold the discharge pipe firmly in place for a few seconds, giving the glue time to set (Figure I).

**If you have removed the outlet fitting from the check valve prior to gluing the connection, make sure to slide the union nut onto the supply pipe before gluing the socket fitting in place.**

Attach the Triton Check Valve to the TidalWave pump by threading the discharge pipe into the pump discharge.

Figure I.

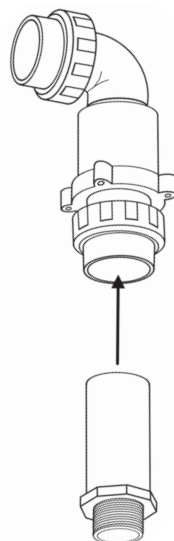

**MD, TW2 and SH Series pumps include fittings that convert the pump discharge to 1 1/2" female threads and are necessary for proper attachment to the TR215CV.**

Place the TidalWave pump with installed Triton Check Valve into the PS3900 Skimmer. Connect the outlet fitting of the Triton Check Valve to the PVC supply line that feeds the waterfall using PVC glue and cleaner. For your convenience; 2" and 1 1/2" outlet fittings are supplied with the Triton Check Valve.

Complete installation by tightening the union nuts on the Triton Check Valve. Hand tighten only. Do not use channel locks to tighten the union nuts.

## AF1000 AUTO FILL KIT

Labeled drill points have been provided for the proper Auto Fill location on either side of the Oasis Skimmer and Pump Vault (Figure K). It is a good idea to completely install the pump, check valve assembly, and discharge hose before you drill for the Auto Fill. This will help you determine the best side of the Skimmer or Pump Vault to place the Auto Fill so that it has proper clearance on all sides.

Once you have determined the location of the Auto Fill, drill a  $\frac{7}{8}$ " hole using a spade bit or hole saw. Insert the Auto Fill making sure the gasket is on the inside of the enclosure and the plastic retaining nut is on the outside. Tighten the retaining nut until snug. Do not over-tighten the retaining nut (Figure J).

Fittings to connect the Auto Fill to a garden hose,  $\frac{1}{2}$ " irrigation line, and  $\frac{1}{2}$ " Sch40 PVC are included in the kit. Wrap the  $\frac{1}{2}$ " male threads on the Auto Fill with thread sealant and install the fitting of your choice. Once water is supplied to the Auto Fill it will maintain the set water level by automatically adding water when the level drops. This level can be adjusted by loosening the wing nut and raising and lowering the height of the Auto Fill float. Use the water line mark on the weir door frame to help establish proper water level.

## OVERFLOW

A drill-point has been provided on the back of the Oasis Skimmer and Pump Vault to show the proper location and elevation to install an Atlantic HA2000 bulkhead fitting for the overflow (not included). See Figure K above for drill-point location. This combination will position the bottom of the overflow pipe approximately 1" above recommended water level. (Note: If a HA2000 bulkhead is not being used, the center point for the hole will have to be recalculated on site.)

Drill a 3" hole and install the bulkhead following the instructions on page 8. Install a 2" MTA and connect the overflow pipe. Apply silicone on the threads of the Male Thread Adaptor (MTA). Screw the MTA into the bulkhead until tight. Use PVC Glue (not included) to glue the PVC flex hose into the MTA.

Figure J.

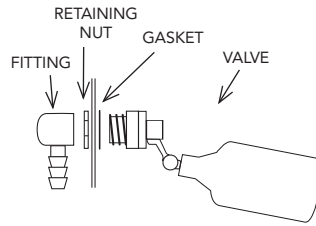

Figure K.

