

POND MINI-VAC®

INSTRUCTIONS

Your Lifegard® Mini-vac can be used with garden hose water pressure or 1½"/1¼" vacuum hose, if pond or water garden is equipped with a wall skimmer or vacuum wall fitting. For vinyl, fiberglass and smooth plaster surfaces, brush nozzle is recommended. Wheel suction nozzle is for use on rougher finishes such as plaster.

For use with garden hose, Mini-vac is equipped with a fine mesh screen bag which can be easily cleaned after use. Most visible debris will be removed by this bag.

For use with vacuum hose, bag removes from suction chamber and vac hose adapter is snapped into place. All debris will be removed through filter system.

OPERATION

INSTRUCTIONS FOR USE WITH GARDEN HOSE

1. Attach net to suction chamber, snap pole to handle bracket and connect garden hose to control valve, leaving in off position.
2. Turn on water at faucet.
3. Place Mini-vac over edge of pond or water garden. Making sure bag is pointed away from you. Turn control valve to full on position.
4. Vacuum, placing brush or wheel suction nozzle against surface to be cleaned.
5. When cleaning is completed, remove bag and empty.

OPERATION

INSTRUCTIONS FOR USE WITH VACUUM HOSE

1. Attach hose adapter to suction chamber, snap pole to handle bracket.
2. Turn on filter system.
3. Fill vacuum hose with water and attach one end to Mini-vac hose adapter and place Mini-vac in water, letting it rest on bottom.
4. Connect remaining end of hose to skimmer suction inlet or wall vacuum fitting.
5. Vacuum with either brush or wheel suction nozzle depending on surface.

HINTS FOR USE

- Be sure you have adequate water pressure to assure proper cleaning.
- Be sure you place enough garden hose in water, to reach the farthest corners. This makes it much easier to maneuver Mini-vac.
- Debris which is too large to pass through brush or wheel suction nozzle can usually be picked up if you remove nozzle from suction chamber.
- Wheel suction nozzle should not be used on vinyl liner surfaces.
- Bag can be cleaned easily by removing bag from top of suction chamber, opening velcro seam at top of bag, rinsing, reseal and place as before.

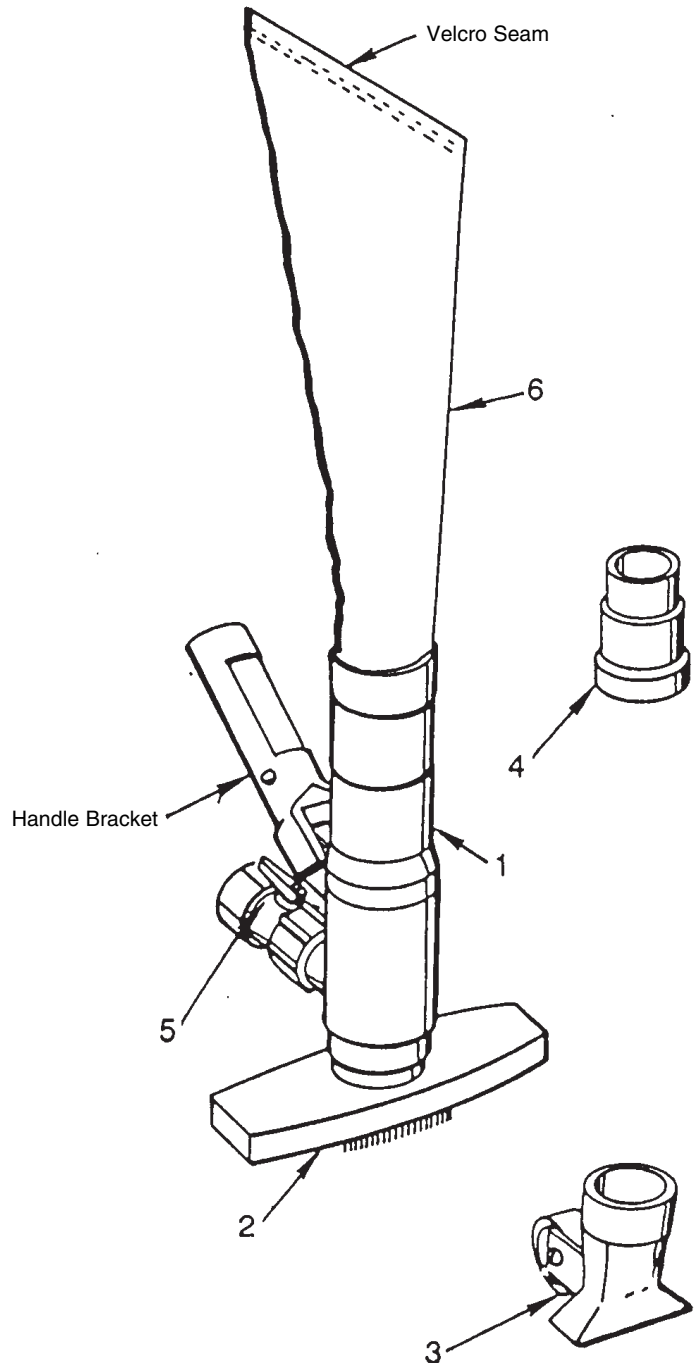

MINI-VAC PARTS BREAK DOWN DRAWING

Item No.	Part No.	Description
1	R201646	Chamber, #204-01 Suction
2	R201656	Brush, #204-02 Nozzle
	R201668	Brush with Soft Bristle, Nozzle
3	R201666	Nozzle, #204-03 Wheel Suction
4	R03080	Adapter, #204-04 Hose
5	R03077	Valve, #204-05 Control
6	R201696	Bag, #204-06 Replacement
Optional	R201716	Socks, #204-08 (3 per bubble pack) Silt

