



Pressurized Bead Filters Installation Instructions

Table of Contents

- Safety Information
- Installation
- Assembly
- Start Up
- Maintenance
- Troubleshooting
- Warranty



Safety Information:

1. Installation should be made by qualified authorized persons and those who have carefully read the following instructions.
2. Operating safety of the filter is maintained only if installation and operation instructions are correctly followed.
3. To reduce the risk of injury, do not permit children to use this product unless they are closely supervised at all times.
4. Incorrectly installed equipment may fail causing severe injury or property damage.
5. In the event of a defective part or operation, contact the manufacturer.

**CAUTION: READ ALL INSTRUCTIONS BEFORE
BEGINNING INSTALLATION OR OPERATION!**

Installation:

BASIC FILTER SET-UP

The placement of the filter is important for proper operation and filtration.

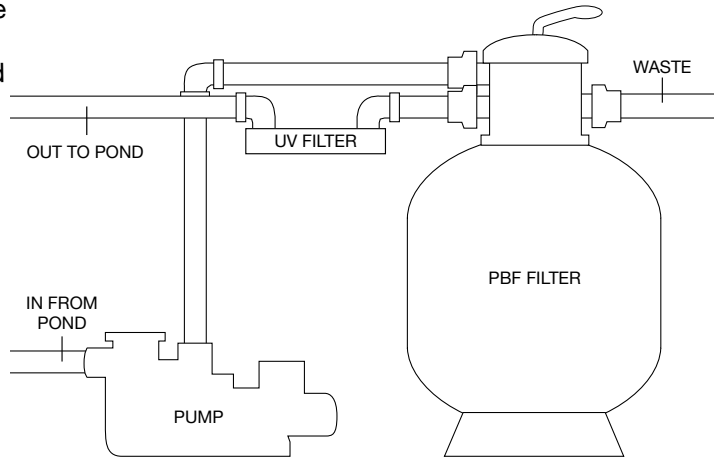

General things to consider for installation:

(Figure 1)

1. If the filter is placed in a room there should be a drain system in the room in case of failure or breakage of plumbing as well as adequate ventilation for pumping equipment.
2. If the system is installed below pond level it is important to install isolating valves to prevent risk of flooding.
3. The filter, pump, plumbing and UV should have adequate space around it for ease of maintenance and service with unit label facing the front to allow identification in case of service difficulties.
4. Plastic fittings should be used for all plumbing connections.
5. Install the filter as close to the pump as possible. Use correctly sized plumbing to minimize friction loss and maximize efficiency.

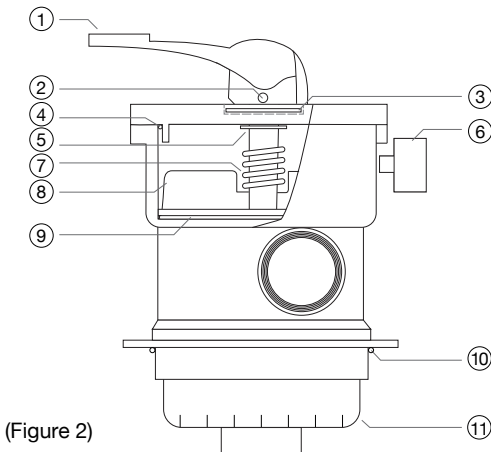

(Figure 2)

Control Valve:

1. Handle
2. Handle Pin
3. Washer
4. Cover O-ring
5. Washer
6. Pressure Gauge
7. Spring
8. Key/Stem Assembly
9. Spider Gasket
10. Body O-ring
11. Diffuser

Assembly:

Before beginning assembly confirm that all components are accounted for and in good condition. Do not begin assembly if parts are missing or components are damaged. Contact EasyPro if items are missing or damaged.

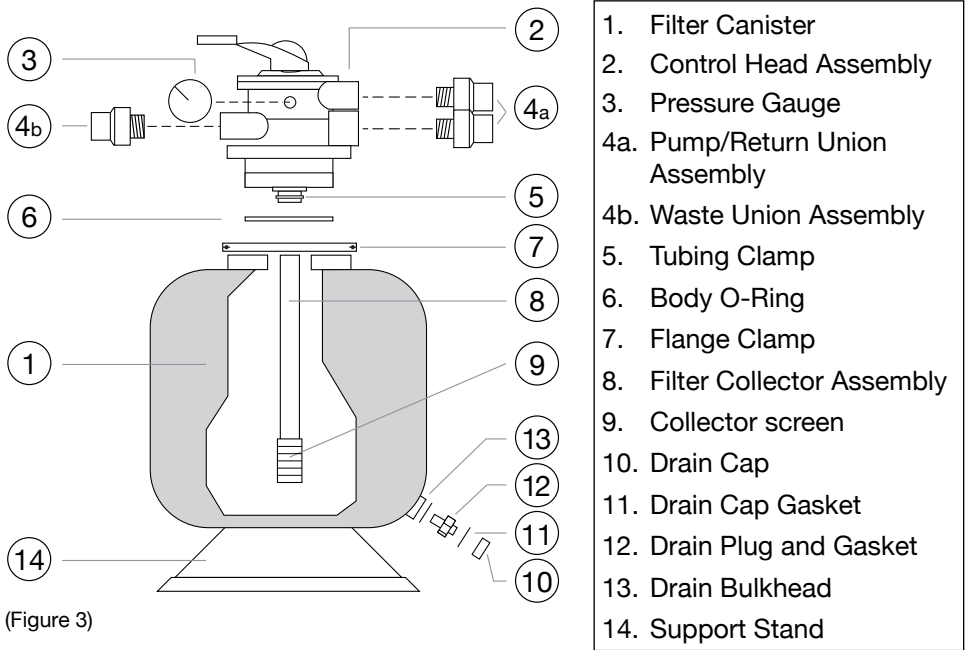

(Figure 3)

1. Ensure that the surface below the filter is sturdy, clean and level. Filters loaded with water can be several hundred pounds and adequate footing that will not erode is essential.
2. Place the filter body in its final position on the supplied support stand.
3. PBF1800 and PBF3600 models come with media installed and control head pre-assembled.

Additional steps for the PBF6000 and PBF10000 units:

4. Install provided Ultimate Tube Media into filter body.
5. Place supplied pipe clamp loosely around bottom of control head assembly. Carefully align the bottom of the control head with the collector assembly

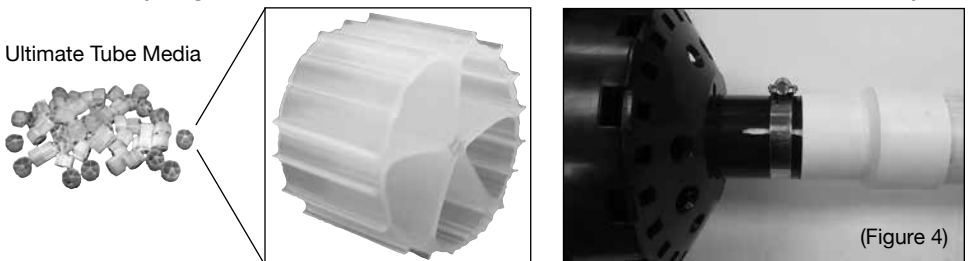

(Figure 4)

stand pipe. Insert stand pipe into head until fully seated. Position pipe clamp as shown and tighten until secure.

6. Insert newly assembled head and stand pipe into filter tub. Be sure to install with body O-ring in place. Slight side to side action can be used to guide assembly through the beads until head is tight against the filter body. Be sure O-ring remains properly in place.

Note: Do not lubricate O-ring, head or filter body.

7. Once positioned in place, secure the control head onto filter body with flange clamp halves.
8. Tighten the bolts on the flange clamp evenly and alternately to ensure equalized tension necessary for proper sealing. Use a large screw driver and tighten firmly. Be sure to align plumbing ports with appropriate plumbing before final tightening of clamp.

All filter units:

9. Install the pressure gauge using teflon tape on threads. Hand tighten only!
10. Install provided union fittings to pump, return and waste line ports. Use only Teflon tape on threads as other sealing materials (paste, silicone, etc.) will void the warranty.
11. Do not over tighten union fittings. Integrated gaskets ensure a water tight seal. Normally hand tightening with one (1) turn with wrench will provide leak proof connection.
12. Glue appropriate PVC plumbing to “PUMP,” “RETURN” and “WASTE” connections.

Start Up and Maintenance:

Always turn off the pump before turning the control valve handle!

1. Set the control head setting to “BACKWASH”. Make sure backwash line is open.
2. Prime and start pump according to pump instructions.
3. Allow tank to be filled with water. Check for leaks and wait for steady flow.
4. Turn off pump. Rotate control head to “FILTER” and be sure return line is open.
5. Restart pump. Check for leaks and wait for steady flow.
6. Make a note of initial pressure on gauge. Pressure will vary by pond and plumbing layout.

It may take one to three weeks for proper balance to be established in the pond ecosystem if a pond is new or has not had previous filtration. Addition of beneficial bacteria products will help equalize pond ecosystem. If the pond is excessively dirty or green (pea soup), a water change is necessary before starting filter.

Backwashing:

Getting rid of excess waste that collects in the filter is simple with the handle-operated backwash system. No messy rinsing of pads or emptying of nets is required; only the turn of a handle.

Always turn off the pump before turning the valve handle!

1. Turn off pump. Rotate control head handle to “BACKWASH” setting. Make sure backwash line is open.
2. Turn pump on and backwash for one to two minutes until clear water is visible.
3. Turn off pump. Rotate control head to “RINSE” to clean valve.
4. Turn pump on and rinse until clear water is visible (one to two minutes).
5. Repeat steps 1-4 two more times for a total of three times.
6. Turn off pump. Rotate control head to “FILTER” and restart pump for normal operation.

Cleaning the Control Valve:

From time to time the control head valve may require cleaning if debris gets caught in various sections of the valve. The handle can be difficult to turn or there may be a leak from the waste port indicating an obstruction in the control head valve.

Always turn off the pump before turning the valve handle!

1. Turn off pump.
2. Rotate handle to “FILTER” (if handle won’t move try rinsing grooves on head top).
3. Clean any surface debris from control head top. This may resolve the issue.
4. Unscrew screws from control head top. Take care not to lose parts.
5. Remove head, spring, and valve to expose trapped debris.
6. Rinse area, check for debris caught under spider gasket and reset spider gasket. Replace spider gasket if damaged.
7. Re-install components.
8. Turn on pump. If leak continues call customer service for assistance.

Winterizing:

Follow these steps for winterizing your EasyPro pressurized bead filter if the filter and pond are shut down for the winter months in freezing climates.

Always turn off the pump before turning the valve handle!

1. Turn off pump. (It is advisable to follow the "Backwashing" procedure before winterizing.)
2. After backwashing, drain filter tank by unscrewing drain cap. Take care not to unscrew entire assembly. Cap should remain off during winter.
3. Rotate control head handle to "WINTER." This will allow water to drain from the valve. Leave valve in this position during the winter.
4. To resume filtration: install drain cap, remove control head, agitate media by carefully stirring it up (take care not to damage collector screen), and reconnect control head and plumbing. Follow "Backwashing" procedure then return to regular operation.

Control Valve Settings:

Setting	Description
Filter	Normal pond filtration
Backwash	Cleaning filter by reversing the flow
Rinse	Used after backwash to flush valve
Waste	By-passes filter for pond draining or lowering
Recirculate	By-passes filter for circulating water in pond when medicating
Closed	Shuts off flow from pump
Winter	Drains the valve for winterizing to prevent freezing when filter is not in use

Part Number	Pond Size	Dimensions (dia x ht.)	Inlet/Outlet sizes	Max gpm flow recommended	Max Pressure*
PBF1800	Up to 1800 gal.	16" x 32"	1½"	30	35 psi
PBF3600	Up to 3600 gal.	19" x 37"	1½"	50	35 psi
PBF6000	Up to 6000 gal.	24" x 44"	2"	70	35 psi
PBF10000	Up to 10000 gal.	31" x 51"	2"	90	35 psi

*Test pressure to 50 psi. Maximum operating pressure listed.

Troubleshooting:

Issue	Possible Causes	Solutions
Valve is leaking from the waste port	<ul style="list-style-type: none">• Handle turned while pump on• Debris caught under spider gasket in control head	<ul style="list-style-type: none">• Clean control head valve (see section under Start Up and Maintenance)
Handle is hard to turn	<ul style="list-style-type: none">• Pump is running• Debris in top valve assembly	<ul style="list-style-type: none">• Turn off pump before turning handle• Clean top portion of control head• Clean control head valve (see section under Start Up and Maintenance)
Gauge does not register any pressure	<ul style="list-style-type: none">• Filter is new• Pump is not sized properly	<ul style="list-style-type: none">• Pressure may build as filter is established• Larger pump may be necessary• Some pumps (low pressure) may not register on pressure gauge, proper filtration may still be maintained despite no pressure reading due to low back pressure media used in filter
Water is brown or murky	<ul style="list-style-type: none">• Improper system circulation• Various situational factors: fish load, rain event, etc.	<ul style="list-style-type: none">• Check pump operation• UV unit may be necessary
Media is coming out waste port	<ul style="list-style-type: none">• Internal parts are damaged• Media lodged in standpipe	<ul style="list-style-type: none">• Check internal parts for damage
Slow flow out of filter and backwashing does not improve flow	<ul style="list-style-type: none">• Pump clogged, malfunctioning or undersized• Pump strainer basket full	<ul style="list-style-type: none">• Check pump for clog or malfunction• Check pump sizing chart for appropriate flow rates/pressure• Check pump strainer basket

FAQ'S:

When do I need to backwash the filter?

It is recommended to backwash the filter every week. Every pond is different, however, and sometimes it may be necessary to backwash less often or more often. Take notice of the pond conditions and observe how often it will be necessary to backwash your filter.

How much head pressure loss should I account for?

There is approximately 5'-12' of head loss in this filter depending on how dirty the filter is.

Can this be my only filter?

Yes, this filter can be your only filter. Other types of filtration can be used in conjunction with these pressure filters as well. Many pond systems use the mechanical filtration of pond skimmers and strainer baskets on external pumps. UV filtration can also be after the EasyPro pressurized filter for increased water clarity.

Limited Warranty:

- This product is warranted against any mechanical or material defects for a period of one year from the date of purchase.
- This limited warranty does not cover accidental damage to the product due to shipping damage, abuse, negligence or improper installation by the installer or user.
- Warranty is voided by the following: product is improperly installed or maintained by user or agent, product is abused, misused or damaged by user or agent, product damage has been caused by failing to turn off pump when switching valve positions, over tightening of the valve or valve fittings, using sealant other than Teflon tape on the valve, using any lubricant on O-ring under the valve, use of non-OEM EasyPro parts or modification of the product.
- An RMA number must be obtained by calling EasyPro Pond Products at 800-448-3873 and be included on package before returning for warranty issues. Return warranty items to: EasyPro Pond Products, 4385 East 110th, Grant, MI 49327. *Be sure to include RMA number, original receipt, name, return address and phone number in package.*
- In the event of a warranty claim, please return the product postage pre-paid with the original receipt for repair or exchange. No warranty claims will be honored without the original receipt.
- The manufacturer or supplier shall not be held liable for any damages caused by defective components or materials of this filter; or for loss incurred because of the interruption of service; or any consequential/incidental damages and expenses arising from the production, sale, use or misuse of this product.
- The manufacturer or supplier shall not be held liable for any loss of fish, plants or any other livestock as a result of any failure or defect of this product.