



# ***Pressurized Bead Filters***

## **Installation Instructions**

### ***Table of Contents***

Introduction

Installation

Assembly

Start up and Maintenance

Troubleshooting

Warranty



### **Introduction:**

Thank you for your purchase of the EasyPro pressurized bead filter. Specifically designed for use with water gardens, koi ponds and hybrid ponds, EasyPro filters offer superior mechanical and biological filtration for clean, clear water. Beneficial bacteria colonize on the surface of the Ultimate Tube Media used in the EasyPro filters. These beneficial bacteria help break down fish-toxic ammonia and create a healthier environment for aquatic life. A properly sized and installed filter will provide excellent water quality for maximum pond enjoyment!

---

***CAUTION: READ ALL INSTRUCTIONS BEFORE  
BEGINNING INSTALLATION OR OPERATION!***

## Installation:

### BASIC FILTER SET-UP

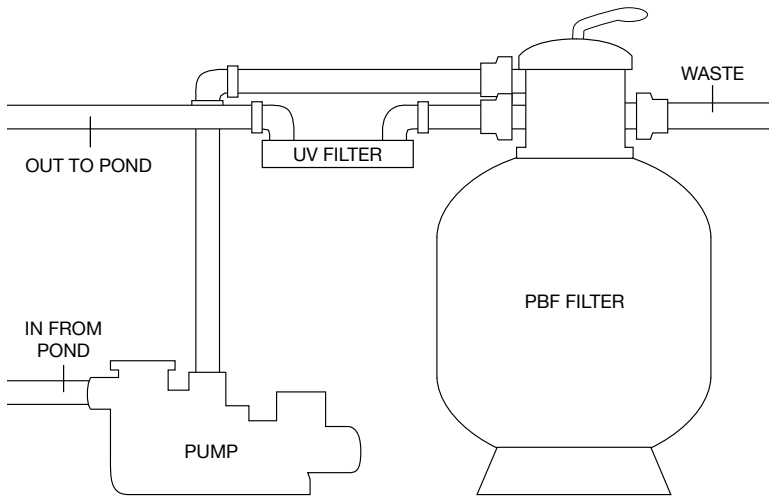

(Figure 1)

The placement of the filter is important for proper operation and filtration.

#### *General things to consider for installation:*

1. If the filter is placed in a room there should be a drain system in the room in case of failure or breakage of plumbing.
2. The filter, pump, plumbing and UV should have adequate space around it for ease of maintenance and service.
3. Plastic fittings should be used for all plumbing connections.
4. Install the filter as close to the pump as possible.

#### **Control Valve:**

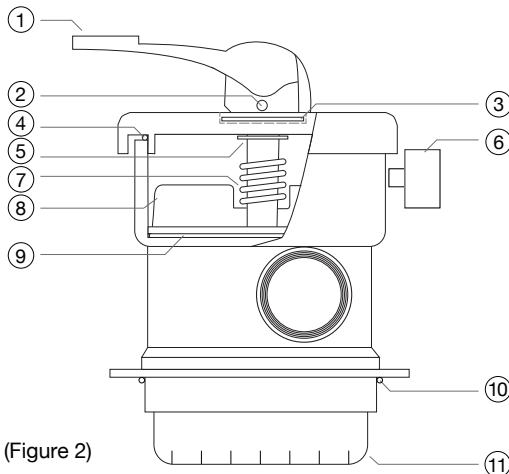

(Figure 2)

- 1 Handle
- 2 Handle Pin
- 3 Washer
- 4 Cover O-ring
- 5 Washer
- 6 Pressure Gauge
- 7 Spring
- 8 Key/Stem Assembly
- 9 Spider Gasket
- 10 Body O-ring
- 11 Diffuser

## Assembly:

Before beginning assembly confirm that all components are accounted for and in good condition. Do not begin assembly if parts are missing or components are damaged. Contact EasyPro if items are missing or damaged.

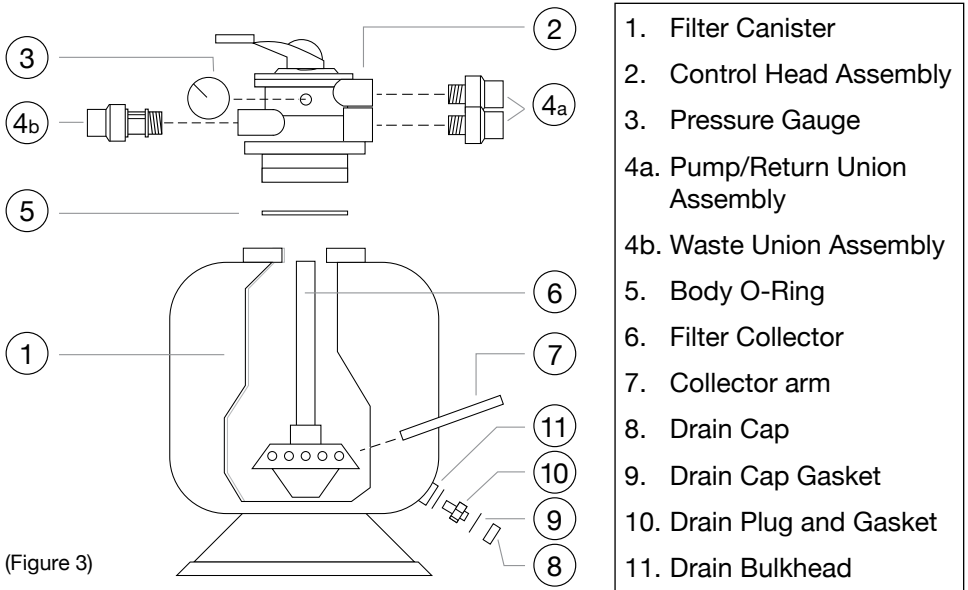

(Figure 3)

1. Ensure that the surface below the filter is sturdy, clean and level.
2. Place the filter body in its final position.
3. Install provided Ultimate Tube Media into filter body. Leave the tubing “protector” device installed until all the media is poured into filter (Figure 4). This prevents media from entering the collector assembly and keeps the collector assembly in place to ensure proper alignment with control head.

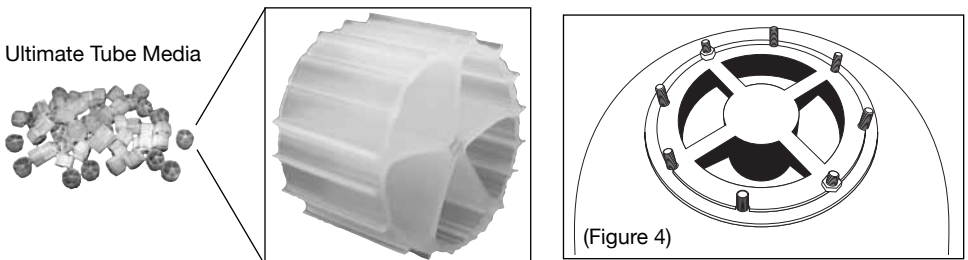

(Figure 4)

- 
4. Remove protector device once all media is in filter body.
  5. Carefully align the bottom of the control head with the collector assembly stand pipe and position the control head into place. Take care not to damage the threads of the bolts when positioning the control head into place.
  6. Once carefully positioned in place, secure the control head onto filter body with supplied nuts and washers.

**TAKE EXTREME CARE TO AVOID CROSS THREADING BOLTS AND OVER TIGHTENING NUTS.**

Tighten the nuts evenly and alternately to ensure equalized tension necessary for proper sealing.

7. Cover the nuts with provided vinyl caps.
8. Install the pressure gauge. Teflon tape must be used to seal threads on gauge. Hand tighten only!
9. Install provided union fittings to pump, return and waste line ports. The union fitting with clear section is designed for the waste line port.

DO NOT use Teflon or pftle sealant on the union threads that go to the control head ports. The union connections supplied need to be fully seated to engage the O-ring which provides the water tight seal.

10. Do not over tighten union fittings. Integrated gaskets ensure a water tight seal.
11. Glue appropriate PVC plumbing to “PUMP,” “RETURN” and “WASTE” connections.

**Start Up and Maintenance:**

Always turn off the pump before turning the valve handle!

1. Set the control head setting to “FILTER”.
2. Prime and start pump according to pump instructions.
3. Check for leaks and steady flow.
4. Make a note of initial pressure on gauge. Pressure will vary by pond and plumbing layout.

If a pond is new or has not had previous filtration, it may take one to three weeks for proper balance to be established in the pond eco-system. Addition of beneficial bacteria products will help equalize pond eco-system. If the pond is excessively dirty or green (pea soup), a water change is necessary before starting filter.

**Backwashing:**

Getting rid of excess waste that collects in the filter is simple with the handle-operated backwash system. No messy rinsing of pads or emptying of nets is

---

---

required; only the turn of a handle.

Always turn off the pump before turning the valve handle!

1. Turn off pump.
2. Rotate control head handle to “BACKWASH” setting.
3. Turn pump on and backwash for one to two minutes until clear water is visible.
4. Turn off pump.
5. Rotate control head to “RINSE” to clean valve.
6. Turn pump on and rinse until clear water is visible (one to two minutes).
7. Repeat steps 1-7 two more times for a total of three times.
8. Turn off pump.
9. Rotate control head to “FILTER” and restart pump for normal operation.

### **Cleaning the Control Valve:**

From time to time the control head valve may require cleaning if debris gets caught in various sections of the valve. The handle can be difficult to turn or there may be a leak from the waste port indicating an obstruction in the control head valve.

Always turn off the pump before turning the valve handle!

1. Turn of pump.
2. Rotate handle to “FILTER” (if handle won’t move try rinsing grooves on head top).
3. Remove handle pin and remove handle.
4. Clean any surface debris from control head top. This may resolve the issue.
5. Unscrew six screws from control head top. Take care not to lose parts including internal o-ring.
6. Remove head, spring, and valve to expose trapped debris.
7. Rinse area, check for debris caught under spider gasket and reset spider gasket. Replace spider gasket if damaged.
8. Re-install components.
9. Turn on pump. If leak continues call customer service for assistance.

### **Winterizing:**

If the filter and pond are shut down for the winter months in freezing climates, follow these steps for winterizing your EasyPro pressurized bead filter.

Always turn off the pump before turning the valve handle!

1. Turn off pump. (It is advisable to follow the “Backwashing” procedure before winterizing.)

2. After backwashing, drain tank by unscrewing drain cap. Take care not to unscrew entire assembly. Cap should remain off during winter.
3. Rotate control head handle to “WINTERIZE.” This will allow water to drain from the valve. Leave valve in this position during the winter.
4. To resume filtration: Install drain cap, remove control head, agitate media by carefully stirring it up (take care not to damage collector arms), and reconnect control head and plumbing. Follow “Backwashing” procedure then return to regular operation.

If filter is buried to control head:

1. Turn off pump. (It is advisable to follow the “Backwashing” procedure before winterizing.)
2. Rotate control head handle to “WINTERIZE.” This will allow water to drain from the valve. Leave valve in this position during the winter.
3. Disconnect plumbing at the unions.
4. Remove the control head from the filter body. Take care not to damage bolts when removing control head.
5. Vacuum the water from the filter body with a wet/dry vacuum. A strainer must be placed over the end of the vacuum hose to avoid vacuuming Ultimate Tube Media. Do not vacuum the media.
6. Carefully position control head back in place on filter body. Connections can remain undone until start up is resumed.
7. To resume filtration: Remove control head, agitate media by carefully stirring it up (take care not to damage collector arms), reconnect control head and plumbing, follow “Backwashing” procedure and return to regular operation.

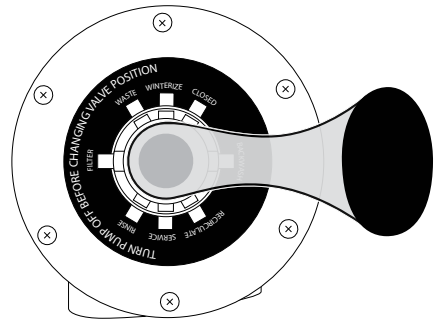

### Control Valve Settings

(Figure 5)

Setting	Description
Filter	Normal pond filtration
Backwash	Cleaning filter by reversing the flow
Rinse	Used after backwash to flush valve
Waste	By-passes filter, for pond draining or lowering
Recirculate	By-passes filter for circulating water in pond when medicating
Closed	Shuts off flow from pump
Winterize	Drains the valve for winterizing to prevent freezing when filter not in use
Service	Do not use

---

## Troubleshooting:

<b>Issue</b>	<b>Possible Causes</b>	<b>Solutions</b>
Valve is leaking from the waste port	<ul style="list-style-type: none"><li>• Handle turned while pump on</li><li>• Debris caught under spider gasket in control head</li></ul>	<ul style="list-style-type: none"><li>• Clean control head valve (see section under Start Up and Maintenance)</li></ul>
Handle is hard to turn	<ul style="list-style-type: none"><li>• Pump is running</li><li>• Debris in top valve assembly</li></ul>	<ul style="list-style-type: none"><li>• Turn off pump before turning handle</li><li>• Clean top portion of control head</li><li>• Clean control head valve (see section under Start Up and Maintenance)</li></ul>
Gauge does not register any pressure	<ul style="list-style-type: none"><li>• Filter is new</li><li>• Pump is not sized properly</li></ul>	<ul style="list-style-type: none"><li>• Pressure may build as filter is established</li><li>• Larger pump may be necessary</li><li>• Some pumps (low pressure) may not register on pressure gauge, proper filtration may still be maintained despite no pressure reading due to low back pressure media used in filter</li></ul>
Water is brown or murky	<ul style="list-style-type: none"><li>• Improper system circulation</li><li>• Various situational factors: fish load, rain event, etc.</li></ul>	<ul style="list-style-type: none"><li>• Check pump operation</li><li>• UV unit may be necessary</li></ul>
Media is coming out waste port	<ul style="list-style-type: none"><li>• Internal parts are damaged</li><li>• Media lodged in standpipe</li></ul>	<ul style="list-style-type: none"><li>• Check internal parts for damage</li></ul>
Slow flow out of filter and backwashing does not improve flow	<ul style="list-style-type: none"><li>• Pump clogged, malfunctioning or undersized</li><li>• Pump strainer basket full</li></ul>	<ul style="list-style-type: none"><li>• Check pump for clog or malfunction</li><li>• Check pump sizing chart for appropriate flow rates/pressure</li><li>• Check pump strainer basket</li></ul>

---

---

## FAQ'S:

### *When do I need to backwash the filter?*

It is recommended to backwash the filter every week. Every pond is different, however, and sometimes it may be necessary to backwash less often or more often. Take notice of the pond conditions and observe how often it will be necessary to backwash your filter.

### *How much head pressure loss should I account for?*

There is approximately 5'-12' of head loss in this filter depending on how dirty the filter is.

### *Can this be my only filter?*

Yes, this filter can be your only filter. Other types of filtration can be used in conjunction with these pressure filters as well. Many pond systems use the mechanical filtration of pond skimmers and strainer baskets on external pumps. UV filtration can also be after the EasyPro pressurized filter for increased water clarity.

### *How do I hide the filter?*

These filters can be housed in pump houses or even buried up to the control head. Having access to the filters is important for backwashing and periodic maintenance.

## Limited Warranty:

- This product is warranted against any mechanical or material defects for a period of one year from the date of purchase.
- This limited warranty does not cover accidental damage to the product due to abuse or negligence by the consumer.
- An RMA number must be obtained by calling EasyPro Pond Products at 800-448-3873 and be included on package before returning for warranty issues.

Return warranty items to:

EasyPro Pond Products, 4385 East 110th, Grant, MI 49327

*Be sure to include RMA number, original receipt, name, return address and phone number in package.*

- In the event of a warranty claim, please return the product postage prepaid with the original receipt for repair or exchange. No warranty claims will be honored without the original receipt.
- The manufacturer or supplier shall not be held liable for any damages caused by defective components or materials of this filter; or for loss incurred because of the interruption of service; or any consequential/incidental damages and expenses arising from the production, sale, use or misuse of this product.
- The manufacturer or supplier shall not be held liable for any loss of fish, plants or any other livestock as a result of any failure or defect of this product.