

ProLine™

By **PONDMASTER®**

**SAVE THESE
INSTRUCTIONS**

PRO 4800 PUMP VAULT and PRO 2000 MINI PUMP VAULT

CARE AND OPERATING INSTRUCTIONS

PRO 4800 ITEM # 02460
PRO 2000 ITEM # 02465

Thank you for purchasing the ProLine by Pondmaster Pump Vault. This unique product is designed for use in continuous flow, self contained waterfall installations. It features:

- Extremely sturdy molded plastic construction
- Reinforced, tight-fitting Vault lid
- Multiple, efficient, non clogging water inlets
- Horizontal or vertical pump placement
- Designed to work with AutoFill valve 12480, Included with PRO4800 Large Pump Vault

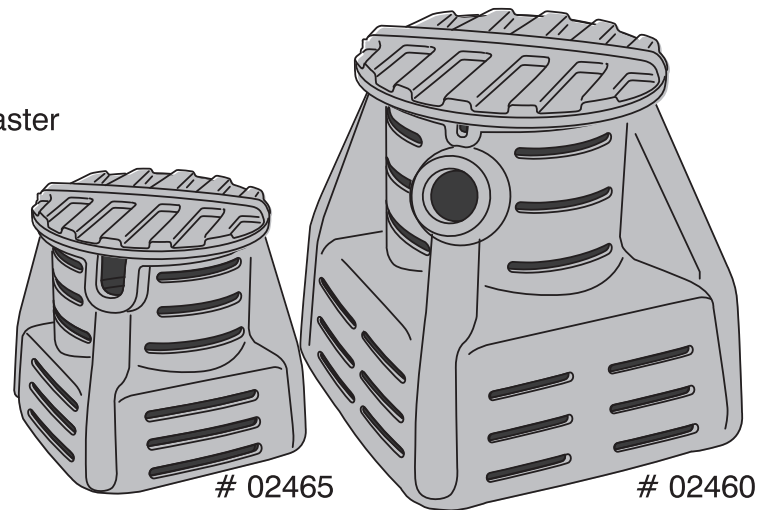

Your ProLine by Pondmaster Pump Vault is strong enough to resist collapsing from pressure of soil and gravel around it and can easily support the weight of surrounding stones and gravel or even an occasional visitor.

CAUTION: Although capable of supporting the weight of an adult, the Pump Vault lid is not designed to support foot traffic.

The Pump Vault includes a flat surface on the back to accommodate an optional automatic fill valve for three season hands free maintenance of the water level. This feature will reduce maintenance requirements and afford you years of service and trouble-free operation.

HOW YOUR PUMP VAULT WORKS

Although the aesthetic appeal of a waterfall is universal, there are many situations where the presence of standing water is a liability, such as where small children might visit unsupervised, or where wind blown litter might accumulate. This lead to the development of waterfalls without visible ponds beneath them. Of course, the water is still there, but the reservoir that feeds the waterfall is filled with gravel. The first waterfalls without ponds had pumps placed directly into the gravel, but they had to be dug out for replacement or service. Your Pump Vault is designed to allow one or more pumps to be placed deep down in the gravel bed and still be easily accessible. In addition, your Pump Vault can be fitted with an optional automatic fill valve to keep the water level in the gravel bed at an optimal level.

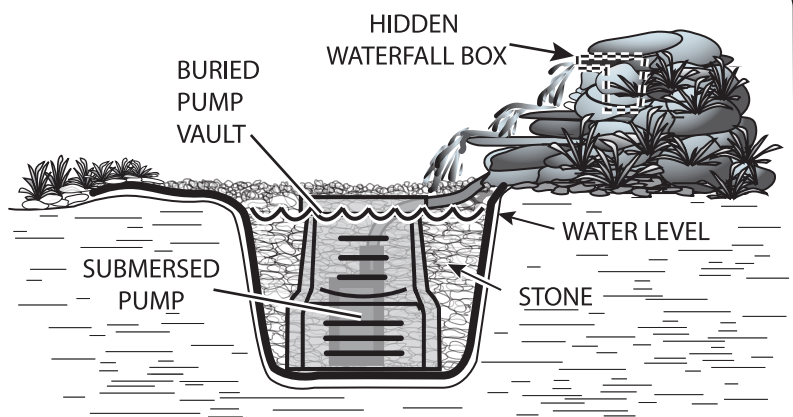

ELECTRICAL PRECAUTIONS

Always use a properly grounded outlet. Do not immerse the plug in water. **DO NOT REACH INTO THE WATER TO REMOVE THE PLUG. TURN OFF CIRCUIT FIRST.** A "drip loop" in the cords should be used. A "drip loop" is a loop in the cord below the level of the receptacle or plug that prevents water from traveling along the cord. The national Electric Code requires that a ground fault interrupter circuit (GFCI) be installed in every branch circuit supplying the fountain or pond equipment. Your dealer can supply GFCI units. **NEVER REMOVE GROUND PIN FROM PLUG.**

WARNING: FOR YOUR PROTECTION, ALWAYS UNPLUG THE UNIT FROM ITS POWER SOURCE BEFORE INSTALLING OR SERVICING. DO NOT REACH, REMOVE OR DISASSEMBLE BEFORE YOU DISCONNECT POWER.

CHOOSING A PUMP

Depending on your set-up you may require a powerful, high head pump or a lower wattage high volume pump with a lower shutoff height. Use the chart below as reference for Pondmaster continuous duty water pumps that will work with the Pondmaster Pump Vaults. The large Pondmaster Pump Vault has an opening that can accept up to 2" reinforced tubing. The Mini Vault will accommodate up to 1 1/2" corrugated tubing.

PONDMASTER PUMPS		GPH @ 1'	GPH @ 5'	GPH @ 10'	Shutoff	Wattage Range*	Vault Option	
Name	Model #						02465	02460
Mag Drive 7	#02527	525	400	100	11' 8"	60 - 32	✓	⊗
Mag Drive 9.5	#02720	800	700	475	12' 10"	90 - 42	✓	⊗
Mag Drive 12	#02722	1000	800	500	13' 6"	100 - 38	✓	⊗
Mag Drive 18	#02728	1325	1100	875	16' 10"	125 - 40	✓	⊗
WFP 2000	#02650	1625	1100	300	13' 2"	140 - 75	✓	✓
WFP 3000	#02660	2450	1850	1300	14' 6"	240 - 120	⊗	✓
HY-Drive 1600	#02663	1750	1450	1050	17' 0"	125 - 110	✓	✓
HY-Drive 2000	#02685	2250	1250	750	15' 0"	195 - 190	✓	✓
HY-Drive 2100	#02665	2100	1775	1325	22' 10"	192 - 142	⊗	✓
HY-Drive 2600	#02667	2600	2500	2025	26' 7"	275 - 220	⊗	✓
HY-Drive 3000	#02690	2800	2100	1350	15' 3"	290 - 230	⊗	✓
HY-Drive 3200	#02680	3700	2450	1000	12' 0"	195 - 185	⊗	✓
HY-Drive 4000	#02675	4100	2800	1575	13' 0"	240 - 225	⊗	✓
HY-Drive 4800	#02670	5200	4100	2550	18' 6"	255 - 245	⊗	✓
HY-Drive 6000	#02683	5500	4700	3400	22' 8"	690 - 550	⊗	✓

* Watts decrease as pump loads increase during normal usage. Examples show range from 1' to shut-off; watts continue to decrease as flow decreases.

CONSTRUCTION PRECAUTIONS

Always contact your local utility companies before you dig and possibly expose and rupture an underground gas, plumbing or electrical conduit. Check property survey for possible buried hazards.

INSTALLATION

1) For the large Pump Vault: Excavate a 3' by 3' hole that is 3' deep. For the Mini Pump Vault dig a 2' by 2' by 2' hole. The dirt from the excavation can be used to build the mound that helps create the height required for a dramatic waterfall effect. Additionally, a protective berm should be built up around the entire edge of the hole. This is a raised edge that will prevent unwanted runoff from the surrounding area from backwashing into your water feature.

2) After excavating the hole, if there are rocks or an abundance of roots, we recommend lining the hole with sand or installing underlayment material as a precaution prior to installing liner. Pondmaster Item # 02125 provides 15' x 6' of durable underlayment.

3) Install an EPDM, PVC or Butyl Rubber pond liner to create a water-tight cavity for the pump vault. A 12' by 12' liner should be sufficient to line the excavation with enough extra liner to catch splash from a small water feature. Larger water features will require a larger liner to cover the larger excavation.

OPTIONAL AUTO-FILL

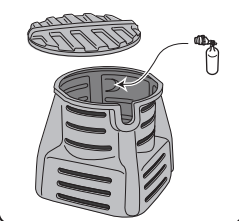

Helpful Hint: Install a piece of PVC pipe next to the vault vertically. Dip a yardstick into pipe to check water level below the rock surface.

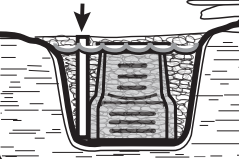

4) At this time if you've chosen to install an optional AutoFill valve for the reservoir, you should do so. The Pondmaster AutoFill Item 12480 is made to fit inside the Pump Vault to regulate the water height. Installation requires boring a 5/8" opening into the flat bulk-head provided opposite the hose opening. The AutoFill then attaches to a garden hose or a 1/2" irrigation line for a constant water feed.

5) Attach tubing to your submersible pump and install inside the Vault. Route tubing through the opening provided. Use the small groove at the top of the pump vault for the pump's power cord to exit without being crimped by the cover.

6) Install the cover and fill the excavation with your choice of graded stone or gravel 1" to 3" in diameter. You can top dress the installation of the Pump Vault with a layer of smaller diameter rocks or a layer of pea gravel.

7) After the earth mound has been formed to create the waterfall, the tubing from the pump can be attached.

8) The final step in installation of the waterfall feature is to fill the hole to capacity with water. If you have not added an auto-fill valve to your system, you must monitor the water allowing the pump to run dry.

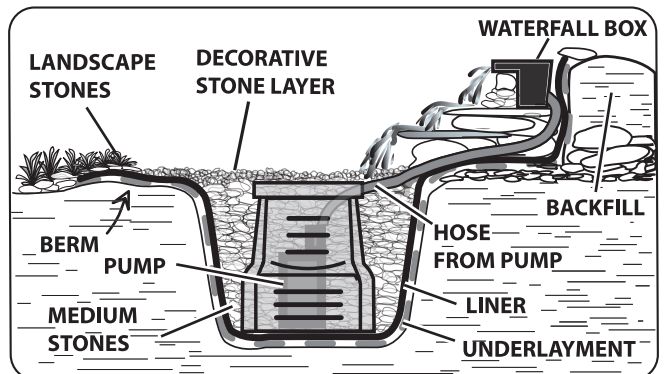
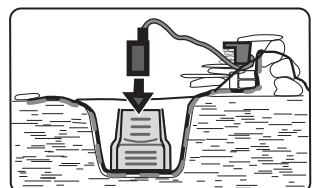
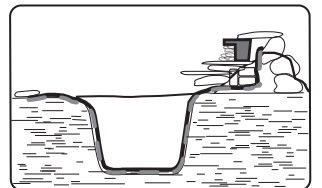
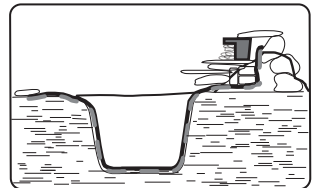
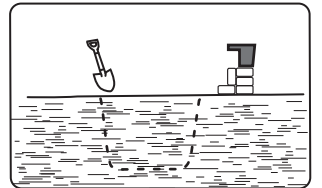

LIMITED TWO YEAR WARRANTY

E.G. Danner Manufacturing will repair or replace any Pro 4800 or Pro 2000 Pump Vault found to be defective within two years of original purchase. For warranty repair, return only the part that is defective to our factory. Please include a dated proof of purchase and \$20 for postage and handling. Damages or injuries resulting from negligence or misuse of the product are not covered by this warranty. This warranty gives you specific legal rights. You may have other rights which vary from state to state.

REPLACEMENT PARTS: Please call (631) 234-5261 or visit our website.