

EX4500 & EX6100



Installation and Service Manual

Please fill in for future reference:

MODEL: _____

SERIAL NUMBER: _____

DATE PURCHASED: _____

* Please fill out the warranty registration card in this manual.

EasyPro
EX4500
S/N: XXXX-XXXXXX

Same label
example for
EX6100

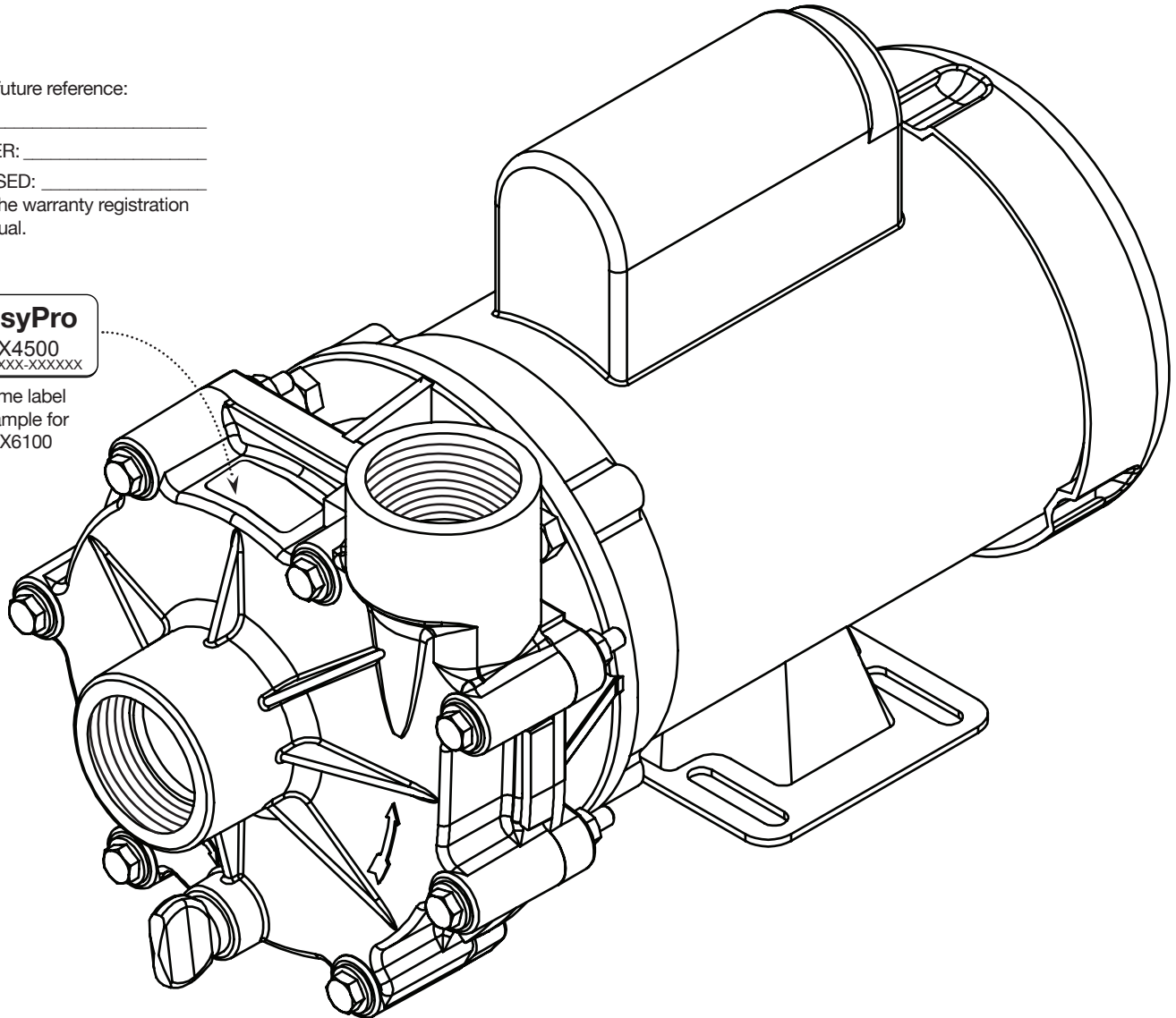

TYPE: STRAIGHT CENTRIFUGAL
MOTOR: NEMA C Face, 56J
HORSEPOWER: 1/8, 1/6, 1/4, 1/3 (1750 RPM)
VOLTAGE: 115/230

INLET: 1 1/2" FNPT
DISCHARGE: 1 1/2" FNPT
MATERIAL: 40% Glass-Filled
Polypropylene

HARDWARE: STAINLESS STEEL
ACCESSORIES: 90 CUBIC INCH STRAINER BASKETS (1 1/2" & 2"),
SWING Check ValveS (1 1/2", 2", 3")
500 CUBIC INCH STRAINER BASKETS
(1 1/2", 2", 3")

WARNING: Please read completely before you install or operate your new pump! This is an external "out-of-pond" pump!
It is NOT submersible! Do NOT allow this pump to become submerged! Never run dry! Max. case pressure.- 65 PSI!



Reliability You Can Count On!

© 2019 EasyPro, Inc

Pg. 1

EX4500 & EX6100

We congratulate you on your choice of the EX4500/EX6100 Centrifugal Pump! It has been carefully designed using the advantages of today's technology and carefully constructed to give you the dependability of yesterday. To insure proper performance, we urge you to carefully follow the instructions in this manual. If you have any questions, call your nearest distributor or EasyPro for assistance.

INSTALLATION

Please read carefully! When properly installed the EX Series Pump will provide dependable trouble-free service.

1. Locate the pump as near the water source as possible. A flooded suction situation is preferred. The pump is not self-priming, therefore, if the fluid level is below the pump, a swing check valve must be installed and the pump primed prior to start-up. (Figure 2)
2. Mount motor base to a secure, immobile foundation.
3. Use only plastic fittings on both the intake and discharge ports. Seal pipe connections with Teflon™ paste. These fittings should be self-supported and in neutral alignment with each port. (i.e. Fittings must not be forced into alignment which may cause premature line failure or damage to the pump volute.) For non-flooded installations, a strainer basket and check valve are recommended.
4. Never restrict the intake. Keep both input and discharge lines as free of elbows and valves as possible. Always use pipe of adequate diameter. This will reduce friction losses and maximize output.
5. This pump is not self-priming! It must not be run dry! We recommend a flooded suction installation. Please read carefully! When properly installed, the pump will provide dependable, trouble-free service.

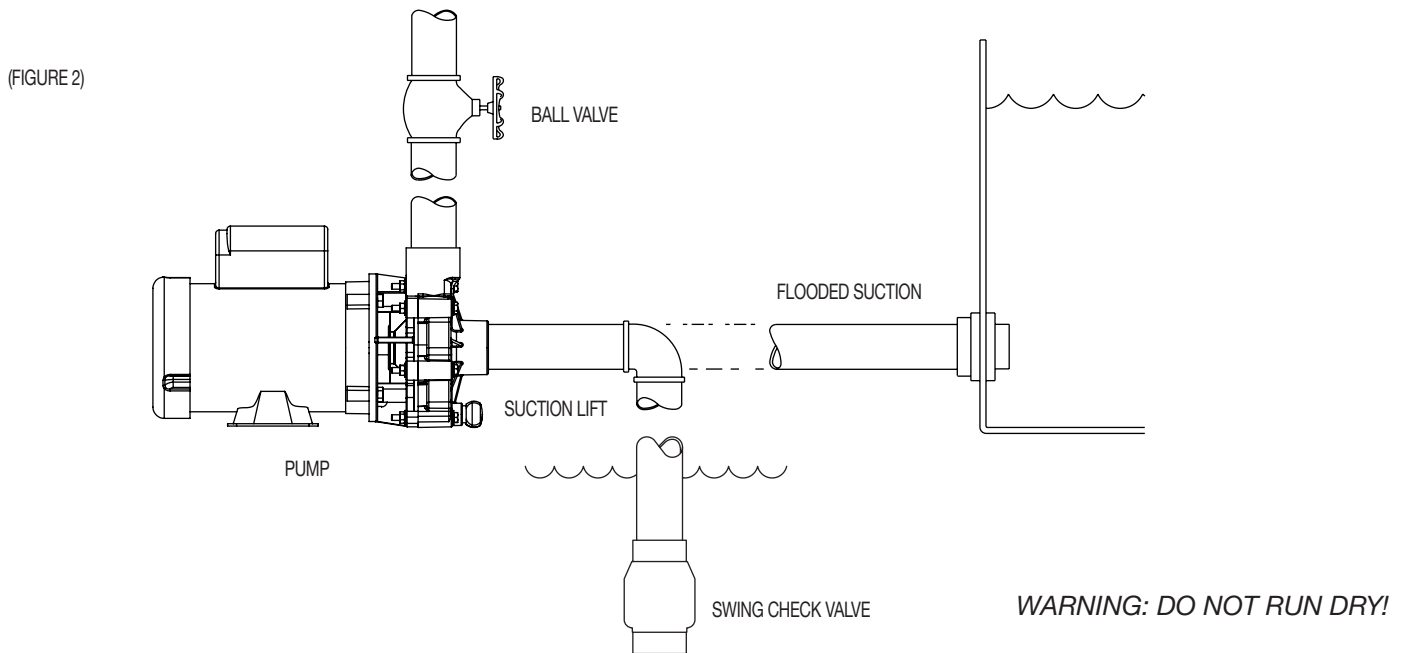

 **WARNING: ALWAYS SHUT OFF ELECTRICAL POWER BEFORE INSTALLATION AND / OR SERVICING THIS PUMP! ALL ELECTRICAL WIRING SHOULD MEET STATE AND LOCAL ORDINANCES. IMPROPER WIRING MAY NOT ONLY BE A SAFETY HAZARD BUT MAY PERMANENTLY DAMAGE THE MOTOR AND/OR PUMP! 230V 50 HZ MOTORS AVAILABLE - CONTACT YOUR SUPPLIER FOR INFORMATION.**

ELECTRICAL HOOK-UP

1. Check that supply voltages match the motor's requirements.
2. Check motor wiring and connect, according to instructions on motor, to match supply voltage.
3. Power cord should be protected by conduit or by cable and be of proper gauge. It should be no longer than necessary.
4. Power should be drawn directly from a box with circuit breaker protection or with a fused disconnect switch.



Reliability You Can Count On!

© 2019 EasyPro, Inc

Pg. 2

EX4500 & EX6100

PUMP END ASSEMBLY

1. Clean and inspect all pump parts (O-ring, seal seats, motor shaft, etc.).
2. Apply sealant to the bracket bore ID wall and around the seal case - follow sealant mfg. instructions. We recommend using Gasgacinch®. Silicone sealant can also be used.
3. Press carbon graphite seal into bracket while taking care not to damage carbon graphite face.
4. Place slinger (rubber washer) over motor shaft and mount bracket to motor.
5. Carefully, lubricate the seal seat elastomer OD and impeller hub ID with water. Press the seal seat into the impeller hub making certain that the ceramic is in evenly — the sealing surface should be parallel with the impeller hub.
6. Carefully lubricate carbon-graphite and ceramic sealing surfaces with CLEAN water. Do not use silicon lubricants or grease!
7. Assemble bracket to motor with four M-bolts
8. Thread impeller onto shaft and tighten! If required, remove motor end-cap and use a screwdriver on the back of motor shaft to prevent shaft rotation while tightening. Replace motor end cap.
9. Seat large O-ring in volute slot and assemble volute to bracket with seven 1/4-20 x 2 3/4" hex cap screws, washers and nuts. Tighten in a cross pattern (30 in-lbf).
10. Install drain plug with its O-ring in volute drain hole.
11. Before operating pump, allow a proper cure time for the sealant used in step 2.

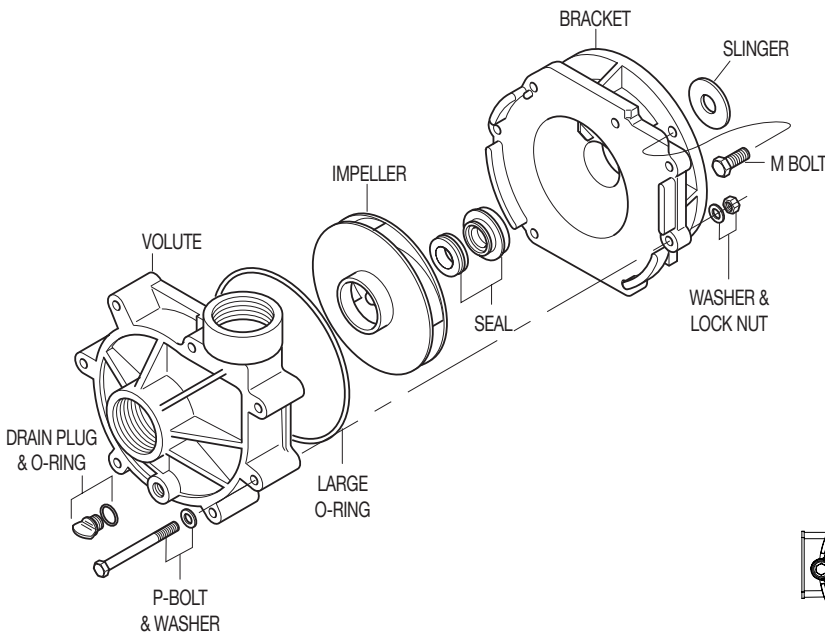

DESCRIPTION	MDM P/N
DRAIN PLUG	1000.110 LG
O-RING, DRAIN PLUG	E014B70
VOLUTE	K000.070 LG
LARGE O-RING	1000.061
IMPELLER	1000.05__*
SEAL - BRASS	1000.0415
SEAL - SS316	1000.0414
BRACKET	K000.030 LG
SLINGER	1000.010V
HARDWARE KIT	1000.502

Note: These part numbers are only for standard models within the EX series. Consult factory for impeller part number.

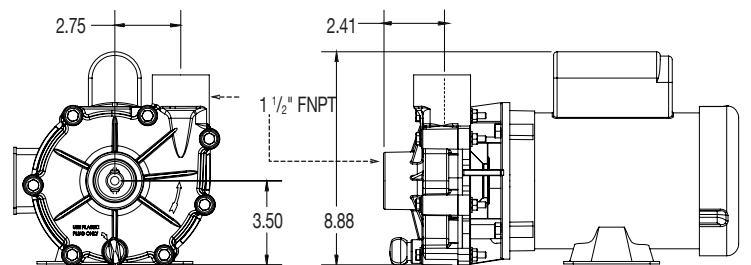

MOTOR ILLUSTRATION IS FOR REFERENCE ONLY.

DISASSEMBLY

1. Shut off power to motor before disconnecting any electrical wiring from the back of the motor.
2. Disassemble volute from bracket by removing the seven 1/4" - 20 threads per inch x 2 3/4" hex cap screws.
3. Remove cap covering shaft at back of motor and with a large screwdriver, prevent shaft rotation while unscrewing impeller.
4. Remove ceramic piece from impeller. (If you are replacing the seal)
5. Detach bracket from motor.
6. Remove carbon-graphite seal from bracket by pressing out from the back. Do not dig out from the front! (If you are replacing the seal)



EX4500 & EX6100

MAINTENANCE

Lubrication

Motor - Permanently Lubricated ball bearings - no service required.
 Rotary Seal - Requires no lubrication after assembly.

**The pump must be drained before servicing or if stored below freezing temperatures. Periodic replacement of seals may be required due to normal carbon wear.*

Symptom	Problem	Resolution
No Flow	Insufficient Prime	Prime system with water and purge all air from suction piping.
		Install check valve.
	Insufficient Power	Verify power supply and connection from panel to pump.
		Verify proper voltage. Some models are dual voltage (115/230).
	Flow Restriction	Ensure valves are open.
		Ensure plumbing is clear, including suction strainers, check valves, etc.
		Verify check valve orientation and direction of permitted flow.
Air leak	Clean out leaves or other debris from basket strainer (if applicable).	
Air leak	Fix air leaks at fittings, connections, strainer basket etc. This typically occurs on the intake side.	
System Incompatibility	Verify hydraulic compatibility: i.e. pump & pipe are sized for the system.	
Low Flow	Air leak	Fix air leaks at fittings, connections, strainer basket etc. This typically occurs on the intake side.
	System Incompatibility	Verify hydraulic compatibility: i.e. pump & pipe are sized for the system.
	Insufficient Power	Verify power supply and connection from panel to pump.
		Verify proper voltage. Some models are dual voltage (115/230).
	Flow Restriction	Ensure valves are open.
		Ensure plumbing is clear, including suction strainers, check valves, etc.
	Cavitation	Clean out leaves or other debris from basket strainer (if applicable).
Prime system with water and purge all air from suction piping.		
Verify airtight plumbing on the suction plumbing especially fittings!		
Sporadic Operation	Insufficient Power	Clean out leaves or other debris from basket strainer (if applicable).
		Increase pipe size where possible.
	Poor Ventilation	Decrease suction pipe length, reduce the number of elbows, etc.
Excessive Noise	Cavitation	Verify hydraulic compatibility: i.e. pump and pipe are sized for the system.
		Verify power supply and connection from panel to pump.
		Verify proper voltage. Some models are dual voltage (115/230).
		Ensure valves are open.
	Flow Restriction	Ensure plumbing is clear, including suction strainers, check valves, etc.
		Verify check valve orientation and direction of permitted flow.

EasyPro Pond Products Limited Warranty

EasyPro Pond Products ("EasyPro") warrants to the purchaser that this product ("Product") will be free from any mechanical or material defects for a period of **18 months** from the date of purchase. EasyPro specifically does not guarantee chemical compatibility, and expressly does not warrant units from any problems caused by chemical attack or failure due to incompatibility of fluid being pumped with pump materials of construction. This warranty only covers properly installed and maintained Products sold by authorized EasyPro Sellers who are subject to and follow EasyPro's quality control standards. Please note that because EasyPro is unable to control the quality of Products sold by unauthorized sellers, unless otherwise prohibited by law, this warranty does not cover Products purchased from unauthorized sellers.

This warranty does not cover normal wear and tear, nor any deterioration suffered through overloading, improper use, negligence, improper installation, acts of God or accident. Similarly, any modification made by the purchaser to the Product will cause the warranty to be null and void. This warranty does not cover any cost associated with the installation or removal of the Product subject to a warranty claim.

All returned items will be inspected to determine cause of failure before a warranty claim is approved. The exclusive remedies provided hereunder shall, upon EasyPro's inspection and option, be either repair or replacement of the Product or parts covered under this warranty.

Making a Claim: A Return Authorization ("RA") number must first be obtained by calling EasyPro at 800-448-3873 or via email at warranty@easypro.com. It is the purchaser's responsibility to pay the return shipping charges. Be sure to include the RA number, original receipt (in the form of an invoice or sales receipt), your name, your return address and your phone number inside of the package. No warranty claims will be honored without the original receipt that shows that your purchase was made from an Authorized EasyPro Seller. Ensure the product is properly packaged and insured for the replacement value. Damage due to improper packaging is the responsibility of the sender.

ALL OTHER EXPRESS OR IMPLIED WARRANTIES INCLUDING MERCHANTABILITY OF FITNESS FOR A PARTICULAR PURPOSE ARE HEREBY LIMITED IN DURATION TO THE DURATION OF THE WARRANTY AS DESCRIBED ABOVE. Some States do not allow limitations on how long an implied warranty lasts, so the above limitations may not apply to you.

EasyPro shall not be held liable for any damages caused by defective components or materials of this Product; or for loss incurred because of the interruption of service; or any consequential/incidental damages and expenses arising from the production, sale, use or misuse of this Product. Some States do not allow the exclusion or limitation of incidental or consequential damages, so the above limitation or exclusion may not apply to you.

EasyPro shall not be held liable for any loss of fish, plants or any other livestock as a result of any failure or defect of this Product. This warranty gives you specific legal rights, and you may also have other rights that vary from State to State.

Name: _____
 Address: _____
 City: _____ State: _____ Zip: _____
 Model: _____ Serial Number: _____
 Date purchased: _____ Where purchased: _____



EasyPro Pond Products
 4385 East 110th, Grant, MI 49327
 800-448-3873 • 231-834-5537 fax
 www.EasyPro.com

Activate your warranty by filling out this form and mailing to EasyPro Pond Products

Gasgacinch® is a registered trademark of Porter Manufacturing. Noryl® is a registered trademark of the General Electric Company. Teflon® is a registered trademark of DuPont Company. 7823 • 10/19

Reliability You Can Count On!

© 2019 EasyPro, Inc

Pg. 4

