

Linear Diaphragm Compressors

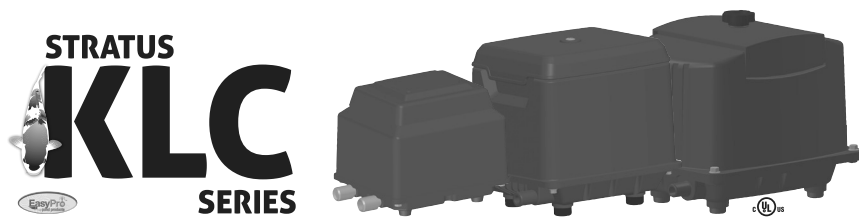

Installation and Service Manual for KLC25, KLC40, KLC60, KLC80, KLC100, KLC120

Thank you for purchasing the Stratus KLC Series linear diaphragm compressor. This instruction manual explains the product operations and gives important precautions regarding its safe use. Please read and follow these instructions to experience years of trouble free service on these top of the line units.

To avoid accident, do not use the compressor in any way other than as described in this instruction manual especially when you see "WARNING". After reading this instruction manual, keep it nearby as a reference in case questions arise during use.

If this instruction manual should become lost or damaged, they are available on our website www.easypropondproducts.com.

PRECAUTIONS

Warning



To avoid electrical shock, special care should be taken when the compressor is in operation. Always unplug the unit from its power source before installing or servicing.

- If the unit falls into water, DO NOT REACH FOR IT: first unplug the unit, and then retrieve it. If any electrical component gets wet, unplug the unit immediately.
- Carefully examine the unit after installation. It should not be plugged in if there is water on parts that are not intended to be wet.
- Do not operate if the power cable or plug is damaged or if the unit is malfunctioning, dropped, or damaged in any way.
- A drip loop shown in *Figure 1*, should be arranged for each. The drip loop is a part of cable below the level of the power outlet or connector that is limply hung.

The drip loop prevents water traveling along the cable coming into outlet:

Figure 1

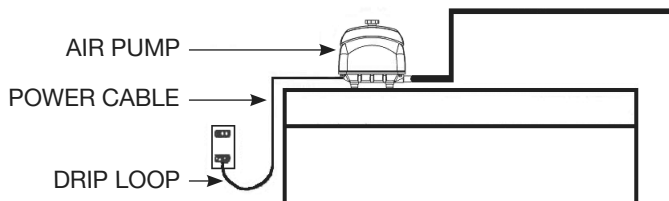

If the electric plug on the power cable gets wet, DO NOT UNPLUG THE UNIT. Disconnect the fuse or circuit breaker supplying power to the compressor. Then unplug and examine for the presence of water in the outlet.

- Do not use the compressor near a flammable liquid such as, gasoline, thinner, etc., as this creates the possibility of explosion.

CAUTIONS FOR USE

- 1 Close supervision is necessary when this compressor is used near children.
- 2 This compressor is designed to handle air only. Do not, under any circumstances, attempt to handle water or other liquids. This may damage the unit.
- 3 The ambient operating temperature for the compressor is between 0°C and 40°C (32°F and 104°F). Operation of the unit outside of this range may result in malfunction or shorten the service life.
- 4 The compressor must have a sufficient room to allow for heat dissipation. Under an extreme operating temperature conditions, which may be caused by failure to observe CAUTIONS #3 and #4, the compressor will automatically switch off until it cools down.
- 5 Always unplug the unit prior to servicing or maintenance. Grasp plug to remove cable from outlet. DO NOT REMOVE BY PULLING ON POWER CABLE.
- 6 Do not use the compressor for any other purpose than what it is designed for.
- 7 Do not store the compressor under freezing conditions.
- 8 Ensure that the compressor is securely mounted or positioned prior to operation.
- 9 Use only a 3-wire extension cord that has a 3-blade grounding plug. Do not use an adapter. See table for correct size extension cord for length required on page 5. **Avoid use of an extension cord if possible.**

INSTALLATION

- 1 Inspect the units for any damage during shipment. Ensure that no parts are missing.
- 2 Do not expose the compressor to excessive weathering or to high moisture concentration. While the compressors are weather resistant, it is still advised that you shelter your compressor from the elements to maximize life of unit. Be sure enough venting is available to allow proper air circulation.
- 3 Ensure that the location is dry and free from excessive dust or debris. Dust protection around the entire unit may be constructed of furnace filters. Ensure that the air circulation is maintained all the time.
- 4 For aeration applications, ensure the unit is placed higher than the surface level of the liquid, otherwise the liquid may run back into the compressor when the power is turned off. A properly installed, low air resistance check valve will prevent back flow and allow placement of the compressor below water surface level.
- 5 Ensure that the compressor is placed horizontally on a strongly built surface.
- 6 Tubing can be attached to the compressor directly to the outlet of the compressor or by using the supplied hose adaptor and clamp. In some cases a valve manifold is used and may require using an adaptor to make a connection to the compressor. Be sure to limit restriction of air output by selecting the proper size tubing and valves. Improper tubing and valve selection will likely result in premature failure cause by the application.

POWER CONNECTION & GROUNDING

- 1 The compressor must be grounded to minimize the possibility of electric shock.
- 2 This compressor is equipped with a power cable having a grounding conductor and a grounding type plug. The plug must be plugged into an outlet that is properly installed and grounded in accordance with all appropriate codes and ordinances.

Warning



Improper installation of the grounding plug can result in a risk of electric shock. If repair or replacement of the cable or plug is necessary, do not connect the grounding wire to either flat blade terminal. The wire with green insulation, with or without yellow stripes, is the grounding wire.

- 3 Check with a qualified electrician or serviceman if the grounding instructions are not completely understood, or if in doubt as to whether the product is properly grounded.
- 4 Do not modify the plug provided; if it will not fit the outlet, have the proper outlet installed by a qualified electrician (*Figure 2*).

Figure 2

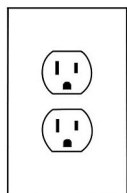
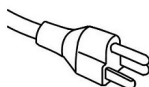

- 5 This compressor is for use on the voltage indicated on the nameplate sticker. Check to be certain that the voltage agrees with your voltage.

OPERATION

When the compressor is connected to a proper receptacle, the compressor will operate. The filter must be periodically cleaned or replaced. The compressor is oil-less and needs no lubrication. This produces clean exhausted air.

- Do not block or restrict the compressor's discharge line.
- If the compressor produces more air than required, bleed excess air volume into atmosphere with a valve. Excessive backpressure will prematurely damage the diaphragm causing more frequent repair.
- In the winter damp air can condense on the inside wall of the hose. This can freeze and eventually block the hose completely. It is important to check the tubing frequently during freezing temperatures.

MAINTENANCE

Periodic maintenance is required for reliable continuous operation. Any maintenance of the compressor other than those described in this manual must be performed by qualified service personnel. Primary regular maintenance for the equipment is mainly:

- Checking the discharge piping as required, and
- Cleaning or changing the filter every 6 months.

Besides the regular maintenance works, customer may inspect and replace the diaphragm and the diaphragm housing.

Note: The illustrations shown here are examples and may not exactly illustrate your equipment.

1. CLEANING OR CHANGING THE FILTER PAD

- a Unscrew the top cover screw, and remove the top cover (*Figure 3*).
- b Take the filter pad out. (Change it with a new filter pad if necessary)
- c Gently dust the filter pad then wash in mild, soapy water and dry completely.
- d Replace the filter pad and the top cover. Secure with the top cover screw.

Figure 3

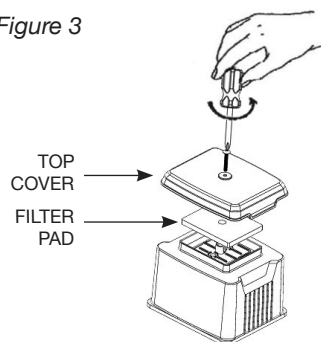

2. CHANGING THE DIAPHRAGM AND DIAPHRAGM HOUSING

- a Place the unit upside down, and unscrew the four (4) screws that are securing the upper housing to the lower housing. *Figure 4*
- b Return the unit to the upright position, and remove the upper housing gently from the lower housing. *Figure 5*
- c Unscrew the screws that are securing the diaphragm housing to the coil frame. The diaphragm housing can be removed after disconnecting the L-tube. *Figure 6*
- d Carefully unscrew the U-nut located in the center of the diaphragm. The screw is covered with an anti-loosening adhesive.
- e Replace it with a new diaphragm frame and new diaphragm housing, and ensure all screws are tightly fastened. *Figure 7*

Figure 4

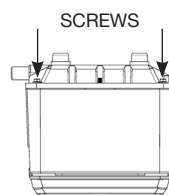

Figure 5

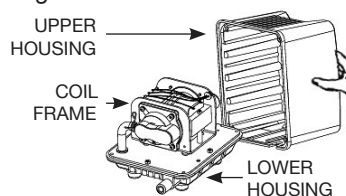

Figure 6

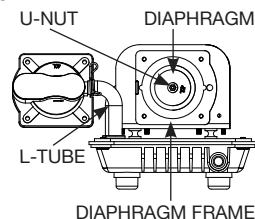
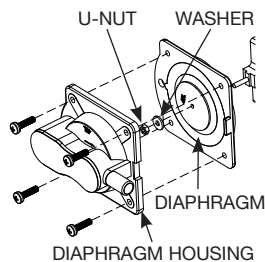

Figure 7



Note: All models up to KLC120 have two (2) diaphragm blocks. It is recommended to replace all diaphragm blocks once a year.

3. LIST OF REPAIR PARTS

Filter Pads

Part #	Fits
KLC25F	KLC25
KLC468F	KLC40-80
KLC100F	KLC100-120

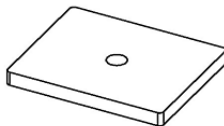

Diaphragm Sets

Includes:

2 × Diaphragm Housing

2 × Diaphragm with Frame

Part #	Fits
KLC25DK	KLC25
KLC40DK	KLC40
KLC68DK	KLC60-80
KLC100DK	KLC100-120

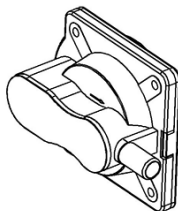

STANDARD SPECIFICATIONS

Model	Discharge Size (nominal)	Frequency (Hz)	Watts	Rated Air Flow (L/min/cfm)	Rated Pressure (psi)	Maximum Pressure (psi) Recommended	Closed Pressure (psi)
KLC25	5/8"	60	23	26/0.92	1.42	2.60	5.0
KLC40	5/8"	60	36	45/1.59	1.85	2.60	5.5
KLC60	5/8"	60	60	68/2.40	2.13	3.00	6.7
KLC80	5/8"	60	70	84/2.97	2.13	3.46	7.8
KLC100	5/8"	60	112	102/3.60	2.56	3.46	7.1
KLC120	1"	60	130	124/4.38	2.85	3.46	7.8

Notes:

- Each model operates on AC, single phase, 115v power.
- An air filter is used at the inlet hole of the compressor. The air filter must be cleaned periodically (Outside installation: every three months, indoor installation: every six months).

MINIMUM GAUGE FOR EXTENSION CORDS

Amps	Volts	Length of Cord in Feet								
		25	50	100	150	200	250	300	400	500
	120v	25	50	100	150	200	250	300	400	500
	240v	50	100	200	300	400	500	600	800	1000
0-2		18	18	18	16	16	14	14	12	12
2-3		18	18	16	14	14	12	12	10	10
3-4		18	18	16	14	12	12	10	10	8
4-5		18	18	14	12	12	10	10	8	8
5-6		18	16	14	12	10	10	8	8	8
6-8		18	16	12	10	10	8	6	6	6
8-10		18	14	12	10	8	8	6	6	4
10-12		16	14	10	8	8	6	6	4	4
12-14		16	12	10	8	6	6	6	4	2
14-16		16	12	10	8	6	6	4	4	2
16-18		14	12	8	8	6	4	4	2	2
18-20		14	12	8	6	6	4	4	2	2

**EXPLODED VIEW:
KLC25**

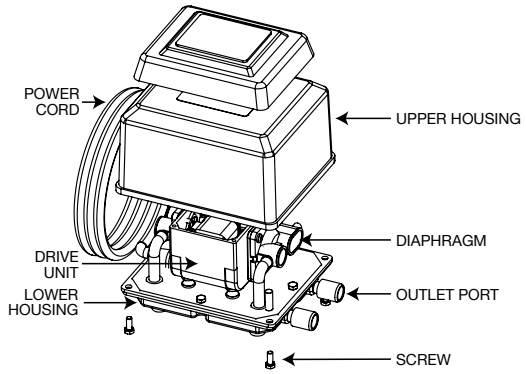

**EXPLODED VIEW:
KLC40, KLC60, KLC80**

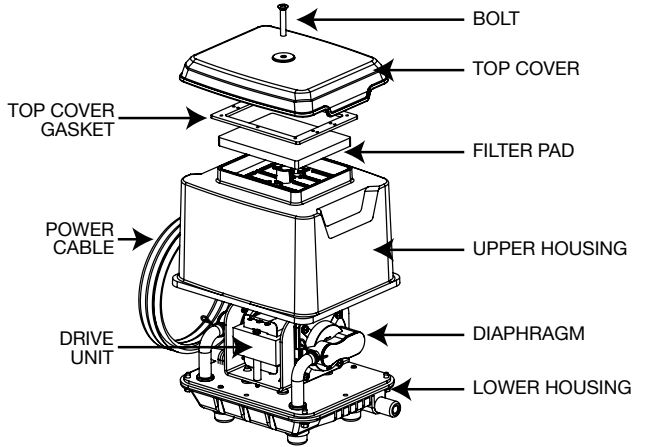

**EXPLODED VIEW:
KLC100, KLC120**

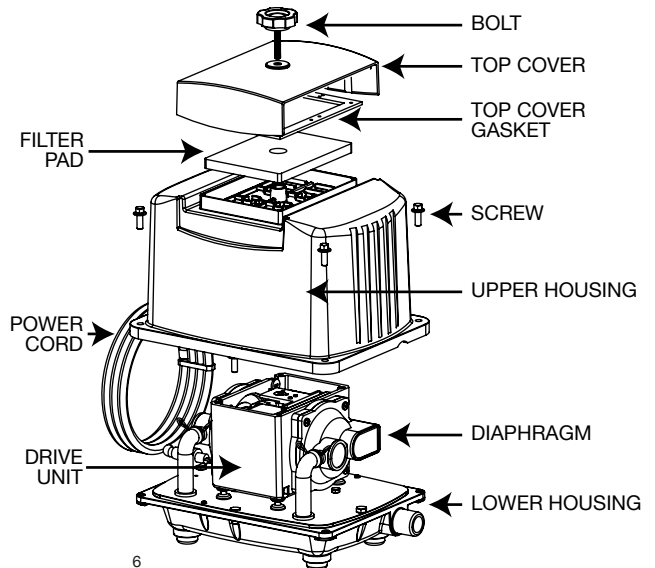

DIAGNOSING MALFUNCTION - No air is discharged

Warning



To avoid electrical shock, special care should be taken when the compressor is in operation. Always unplug the unit from its power source before installing or servicing.

Symptom	Possible Cause	Point to Check Up	Remedy
Pump fails to work	Electrical connection →	Plug and outlet →	Plug securely into outlet
	Wire cut inside cord →	Check with tester →	Change power cable, electromagnet, lead wire
Pump works but produces loud, irregular noise and/or no air	Diaphragm damaged	Remove upper, lower housing and trace source of cause →	Exchange casing or diaphragm block
	Faulty valve		
	Valve chamber cover out of place		
Pump works but no air comes from reservoir	Faulty piping connection →	Rubber hose out of place or broken →	Repair or replace new one
	Faulty filter →	Filter clogged →	Clean, wash and dry filter
	Pump runs normally →	Air line clogged →	Clean properly

Caution:

- For other troubles contact seller or manufacturer for advice
- Change diaphragm once a year.
- During operation, do not touch the lower housing with bare hands as the temperature will become about 70°C (158°F). (This temperature will not affect the performance of the pump.) A thermal overload will turn off the compressor when temperature gets too high. Unit will come back on after it cools down. Causes for excess heat should be determined and eliminated. Common causes include lack of ventilation and excess back pressure in the system. Remedies for these causes should be found to avoid over heating of the units.
- Proper sizing and selection of tubing, length of tubing, number of diffusers and depth of diffusers are all important factors for maximizing the performance of KLC linear diaphragm compressors. These units are designed to produce fairly large volumes of air at low pressure. Extra back pressure created by restrictive tubing, undersized or clogged diffusers, incorrect valve systems or deeper water can cause excess wear and tear on the rubber diaphragms. While replacing the diaphragms is easy to do, too much back pressure may require more frequent repair.

Warranty:

This product is warranted against any mechanical or material defects for a period of three years from the date of purchase (air filter and diaphragms are wearable items and are not covered). Warranty only covers properly installed and maintained units.

The warranty does not cover normal wear and tear, nor any deterioration suffered through overloading, improper use, negligence or accident. Similarly, any modification made by the purchaser to the product will cause the warranty to be null and void.

All returned items will be inspected to determine cause of failure before warranty is approved.

Warranty does not cover any cost associated with the installation or removal of the product subject to warranty claim.

An RA number must be obtained by calling EasyPro Pond Products at 800-448-3873. It is your responsibility to pay the return shipping charges. Be sure to include the RA number, original receipt (in the form of an invoice or sales receipt), name, return address and phone number inside of the package. No warranty claims will be honored without the original receipt.

Ensure the product is properly packaged and insured for the replacement value. Damage due to improper packaging is the responsibility of the sender.

The manufacturer or supplier shall not be held liable for any damages caused by defective components or materials of this product; or for loss incurred because of the interruption of service; or any consequential/incidental damages and expenses arising from the production, sale, use or misuse of this product.

The manufacturer or supplier shall not be held liable for any loss of fish, plants or any other livestock as a result of any failure or defect of this product.

Please keep a copy of receipt for your records

Part/Model # _____

Serial # _____



800-448-3873 • Grant, Michigan

www.easypropondproducts.com • info@easypropondproducts.com