

PARTS LIST		HORIZONTAL WATER FEATURE PUMP			8/30/2019	
ITEM	PART No.	DESCRIPTION	QTY	SIZE	MATERIAL	NOTES
1	143-000-33	Hex.Tapping Screw	2	M5x20	SUS304	
2	003-190-10	Gland	1		SUS316	
3	001-943-36	Cabtyre Cable Set (20')110V-60Hz(USA)	1	STOW3x1.25mm2(CSA)	LB	
4	140-000-34	Hex.Bolt (w/Spring/Plain Washer)	4	M5x25(14L)	SUS304	
5	122-003-17	O-Ring	4	P-5(4.8xd1.9)	NBR	*
6	051-000-34	Motor Head Cover	1		Resin	
6-1	165-000-04	Rubber Feet (for Head Cover)	1	28x38x15t	NBR	
7	121-001-06	Packing	1	d110.5xd115.5x4.5t	NBR	*
8	076-000-55	Capacitor 110V-60Hz(USA)	1	28MF-220VAC		interchangable with OLD part# 076-000-23
9	143-000-22	Tapping Screw	1	M3x10	SWCH	
10	143-086-22	Pan Screw (w/Spring Washer)	2	M4x8	SWRM	
11	143-000-21	Pan Screw	4	M4x115(30L)	SS	
12	127-000-23	Capacitor Fixing Plate	1		SPCC	
13	068-000-27	Handle	1		Resin	
14	009-000-47	Earth Terminal	1Set	1.25mm2x200L		
15	140-452-11	Hex.Bolt (w/Spring/Plain Washer)	1	M4x8	C3604	
16	050-000-34	Motor Bracket	1		ADC	
17	142-388-11	Wave Washer	2	6201(D=30.6)	S65CM	
18	052-100-15	Bearing	1	6201ZZC3		
19	055-002-17	Rotor (1st Rev)	1Set	w/Bearing		DISCONTINUED
	055-000-94	Rotor (2nd Rev)	1Set	w/Bearing		
20	056-002-22	Stator (w/M.Frame)110V-60Hz(USA)	1Set	w/Miniature Protector		
21	052-100-15	Bearing	1	6201ZZC3		
22	060-000-65	Bearing Housing (1st Rev)	1		ADC	
	060-001-18	Bearing Housing (2nd Rev)	1		ADC	
23	121-001-11	Packing	1	40PU2.15-52/62	NBR	*
24	025-000-41	Mechanical Seal	1	D-12R	SiC	
25	030-000-08	Oil Lifter	1	D-12B	Resin	
26	029-000-42	Oil Casing	1	40PU2.15-52/62	Resin	
27	141-029-18	Hex.Cap Nut	4	M6	SUS304	
28	121-246-11	Packing	1	d10.3xd16x2t	PE	*
29	035-127-15	Oil Plug	1	M10x15	SUS304	
30	122-131-15	O-Ring	1	G-100(99.4xd3.1)	NBR	*
31	143-000-26	Truss Screw (w/O-Ring)	4	M6x20(P-5,NBR)	SUS304	*
32	040-139-16	Impeller Washer	1	d9.2xd17x2t	SUS304	
33	021-007-34	Impeller (60Hz)	1	3-PL	Resin	
34	143-173-14	Truss Screw (w/Plain Washer)	1	M5x10	SUS304	
35	020-002-10	Pump Casing	1	3-PL	Resin	
35-1	165-000-05	Rubber Feet(for P.Casing)	2	23.5x48x15t	NBR	
36	140-435-18	Hex.Bolt (w/Plain Washer)	4	M6x30	SUS304	
	173-002-57	Packing O-Ring Set	1Set	(Marked by *)		
5	122-003-17	O-Ring (Head Cover Fixing Screw)	4	P-5(4.8xd1.9)	NBR	*
7	121-001-06	Packing (Head Cover/M.Frame)	1	d110.5xd115.5x4.5t	NBR	*
23	121-001-11	Packing (M.Frame/P.Casing)	1	40PU2.15-52/62	NBR	*
28	121-246-11	Packing (Oil Plug)	1	d10.3xd16x2t	PE	*
30	122-131-15	O-Ring (O.Casing/P.Casing)	1	G-100(99.4xd3.1)	NBR	*
31	122-003-17	O-Ring (O.Casing Fixing Bolt)	4	P-5(4.8xd1.9)	NBR	*
		Lubricant		Liquid Paraffin VG32 150ml		

PARTS LIST		HORIZONTAL WATER FEATURE PUMP			8/30/2019	
ITEM	PART No.	DESCRIPTION	QTY	SIZE	MATERIAL	NOTES

EXPLODED VIEW 3-PL

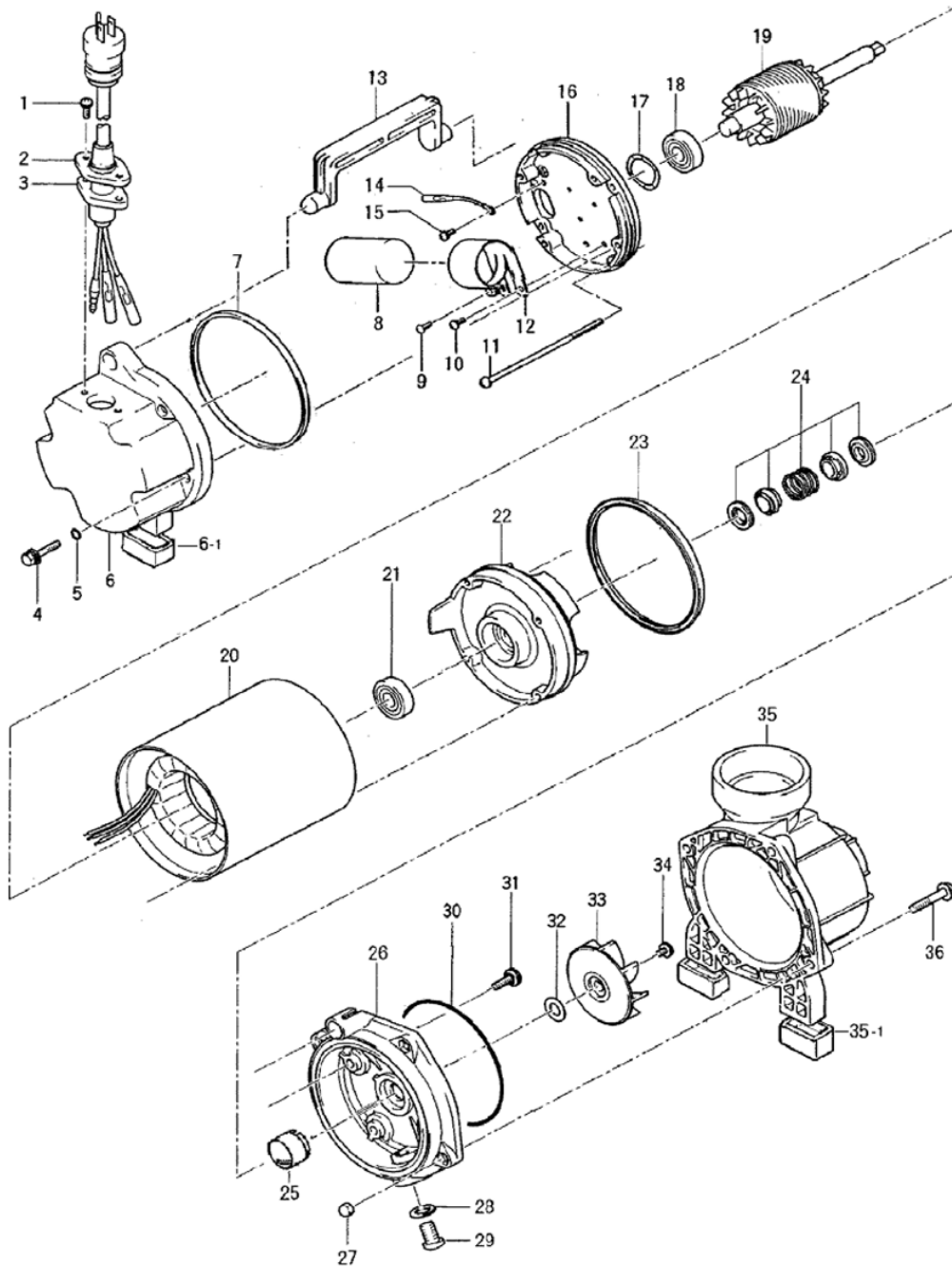

C-00953-1